

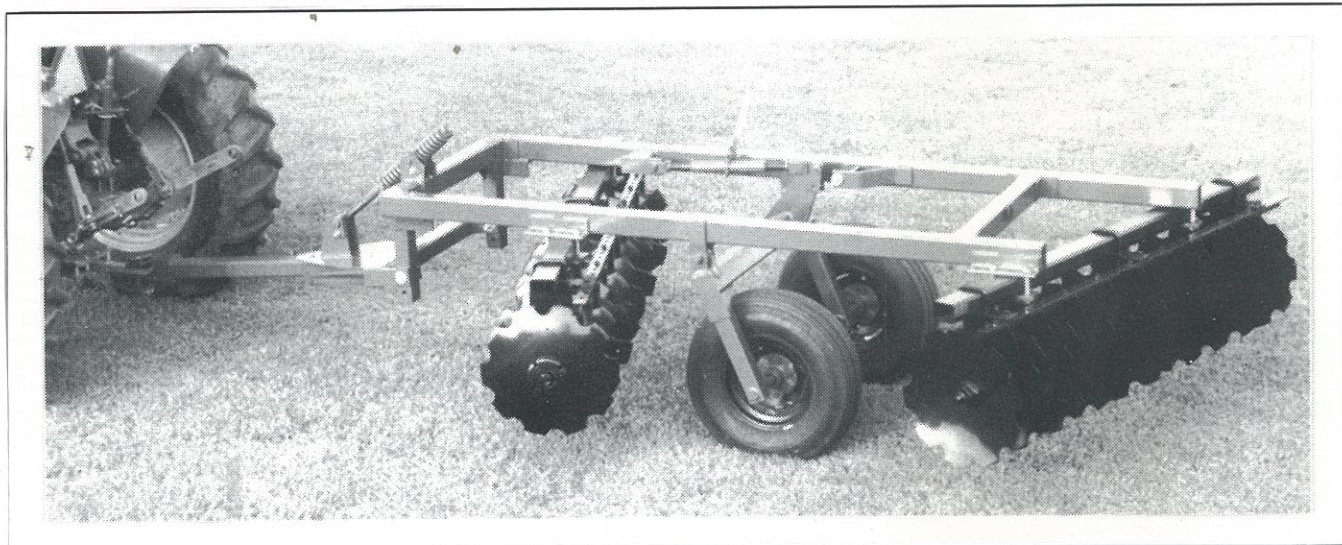

D-41 & C-41 WHEEL OFFSET

OPERATIONMAINTENANCE**SET-UP
INSTRUCTIONS**



AMCO MANUFACTURING COMPANY

800 South Industrial Parkway P.O. Box 1107
Yazoo City, Mississippi (MS) 39194 USA
(662) 746-4464 Toll free 800-748-9022 Fax (662) 746-6825
www.amcomfg.com

TO THE PURCHASER

The care you give your new AMCO Offset Disk Harrow will greatly determine the satisfaction and service you will obtain from it. By observing the instructions and suggestions in this manual, your AMCO Offset Harrow will serve you well for many years.

As an Authorized Dealer, we stock Genuine AMCO Parts, which are manufactured with the same precision and skill as the original equipment. For best performance and longer life use only Genuine AMCO replacement parts. Our factory trained staff is kept fully informed of the most efficient methods of servicing AMCO equipment and is ready and able to assist you.

When you sell your Harrow you should pass this manual to the new owner.

If you should require additional aid or information, contact us.

YOUR AUTHORIZED AMCO DEALER

OSHA requires that as a farm employer you meet certain safety requirements. Become familiar with and comply with those requirements. Be sure anyone who operates this equipment understands all safety related items. If this harrow is repainted, be certain new decals are ordered. Decals pertaining to personal safety must be replaced.



Look for this symbol to point out important safety precautions. It means – ATTENTION! Become alert! Your safety is involved.

To insure efficient and prompt service, please provide the model number and serial number of your AMCO Harrow in all correspondence or contacts. Remember, the right and left hand sides of the harrow are determined by standing at the rear of the harrow and facing the direction of travel. AMCO always strives to make improvements on equipment. AMCO is not responsible for changes or additions to equipment previously sold.

MODEL NUMBER

SERIAL NUMBER

TABLE OF CONTENTS

To the Purchaser	i
Table of Contents	1
General Specifications C-41	2
General Specifications D-41	3

PARTS LIST

Main Frame, Rockshaft and Pull Tongue	4
Hub and Wheel	6
Feathering Blade (Optional)	7
Hydraulic Cylinder 3 x 8 (Optional)*	8
C-41 Front Gang Frame	10
C-41 Rear Gang Frame	12
D-41 Front Gang Frame	14
D-41 Rear Gang Frame	15
Decals	17
Safety Suggestions	18
General Torque Specifications	19

OPERATORS MANUAL

Assembly Instructions	20
Lubrications	22
Operating Instructions	24
Maintenance	30
Disk Blade Failure	31

Rev. 3/12/12

C41 WHEEL OFFSET TANDEM

General Specifications

AXLES:	1-1/8" square high carbon, cold rolled steel	BEARINGS:	Regreasable triple sealed gang bearings
BLADES:	20" X 7 Ga. Plain	WHEELS:	2 - 14 X 6" 6 Bolt Hubs
SPACING:	7 Inches	WEIGHT:	79 - 83 lbs. per blade 265 - 277 lbs. per foot
SCRAPERS:	Heavy duty high carbon steel blades on 1/2 X 1-1/2" shanks mounted on 2 X 2 X 3/8 angle iron bars	TRANSPORT WIDTH:	Width of cut plus 6 inches Plus additional 10 inches with feathering blade
GANG ANGLE:	17° to 23° front and rear		
TONGUE:	Adjustable		

Model No.	Cutting Width	No. of Disks	No. of Bearings	Disk Size & Type	Approx. Shipping Weight	Recommended Drawbar Horsepower
C41-2020	6'0"	20	6	20" Plain	1,665	25-40
C41-2220	6'7"	22	6	20" Plain	1,750	30-45
C41-2420	7'2"	24	6	20" Plain	1,900	35-50
C41-2620	7'9"	26	6	20" Plain	2,050	40-55

OPTIONAL EQUIPMENT

Tongue Jack
Hose Holder
Hose Kit
Ratchet Jack
3" X 8" X 1-1/4" Hyd. Cyl. W/Stroke Control
Feathering Blade W/Scraper for Rear Gang

20" X 7 Ga. C.O. Blades
22" X 7 Ga. C.O. Blades
22" X 7 Ga. Plain Blades
22" X 1/4 C.O. Blades
22" X 1/4 Plain Blades

RECOMMENDED TIRE SIZE

9.5L X 14 - 8 Ply Tubeless Tire

NOTE: Use of disk on tractors with higher than recommended Drawbar Horsepower will cause excessive maintenance cost and may void your warranty.

D41 WHEEL OFFSET TANDEM

General Specifications

AXLES:	1-1/8" square high carbon, cold rolled steel	BEARINGS:	Regreasable triple sealed gang bearings
BLADES:	22" X 7 Ga. Plain	WHEELS:	2 - 14 X 6" 6 bolt hubs
SPACING:	9 Inches	WEIGHT:	96 - 110 lbs. per blade 256 - 294 lbs. per foot
SCRAPERS:	Heavy duty high carbon steel blades on 1/2 X 1-1/2" shanks mounted on 2 X 2 X 3/8 angle iron bars	TRANSPORT WIDTH:	Width of cut plus 6 inches Plus additional 10 inches with feathering blade
GANG ANGLE:	17° to 23° front and rear		
TONGUE:	Adjustable		

Model No.	Cutting Width	No. of Disks	No. of Bearings	Disk Size & Type	Approx. Shipping Weight	Recommended Drawbar Horsepower
D41-1622	6'0"	16	6	22" Plain	1,765	25-40
D41-1822	6'9"	18	6	22" Plain	1,850	30-45
D41-2022	7'6"	20	6	22" Plain	2,000	35-50
D41-2222	8'3"	22	6	22" Plain	2,150	45-60
D41-2422	9'0"	24	8	22" Plain	2,300	55-75
D41-2622	9'9"	26	8	22" Plain	2498	60-75

OPTIONAL EQUIPMENT

Tongue Jack
 Hose Holder
 Hose Kit
 Ratchet Jack
 3" X 8" X 1-1/4" Hyd. Cyl. W/Stroke Control
 Feathering Blade W/Scraper for Rear Gang

20" X 7 Ga. C. O. Blades
 20" X 7 Ga. Plain Blades
 22" X 7 Ga. C. O. Blades
 22" X 1/4 C.O. Blades
 22" X 1/4 Plain Blades

RECOMMENDED TIRE SIZE

6.70 X 14 or 9.5L X 14 - 8 Ply

NOTE: Use of disk on tractors with higher than recommended Drawbar Horsepower will cause excessive maintenance cost and may void your warranty.

MAIN FRAME, ROCKSHAFT, & PULL TONGUE

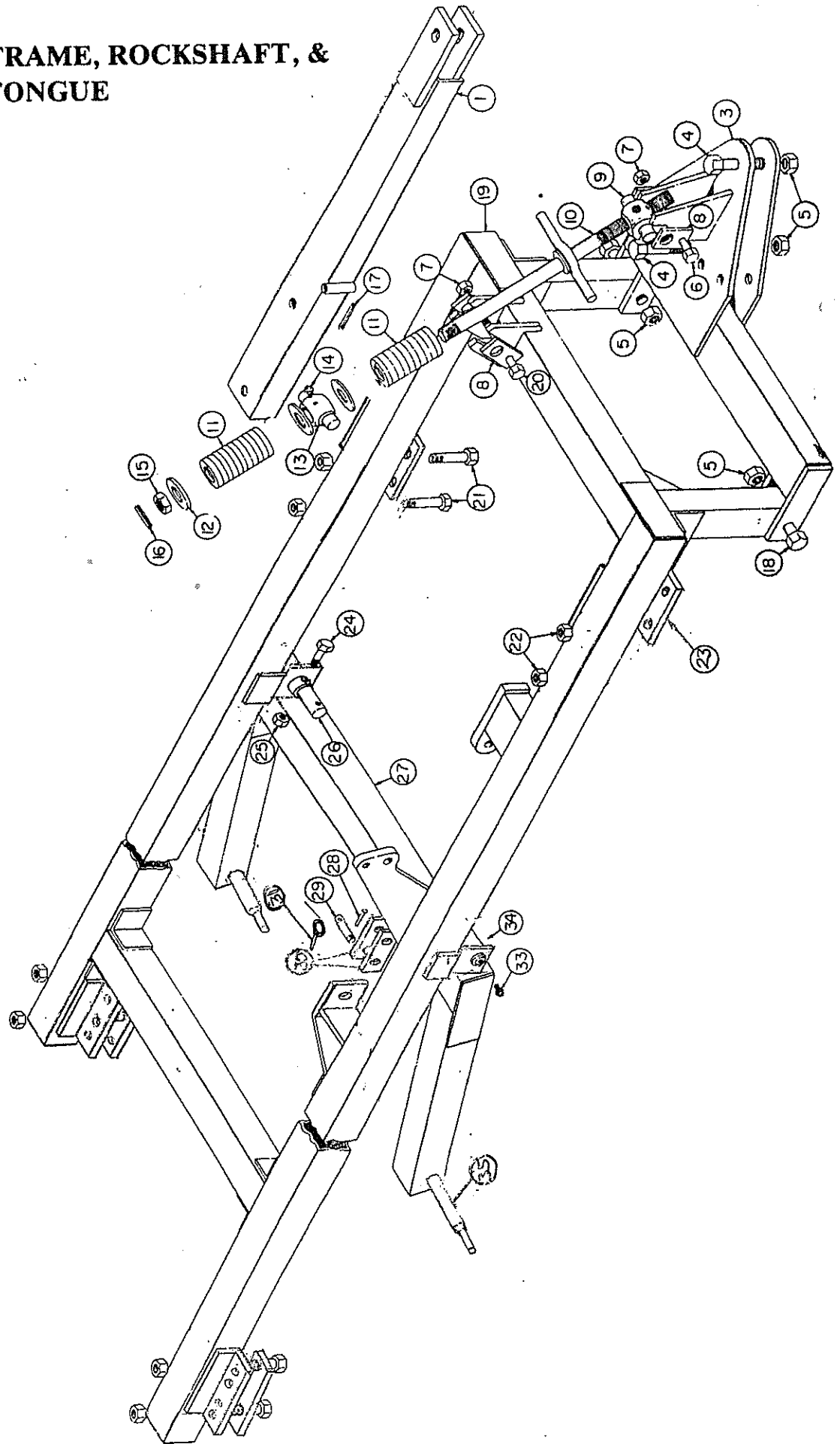

AMCO
C41 & D41
MAIN FRAME, ROCKSHAFT, & PULL TONGUE

<u>Ref. No.</u>	<u>Part No.</u>	<u>Description</u>	<u>No. Req'd.</u>
1	20532	Assy. Pull Tongue	1
3	20533	Assy. Cross Tongue	1
4	10671	Botl - Hex 3/4" x 5" NC, PLT, Gr. 5	2
5	10300	Nut - Lock 3/4" NC, PLT, Gr. B	12
6	10666	Botl - Machine 5/8" x 5" NC, PL, Gr. 5	1
7	10299	Nut - Lock 5/8" NC, PL	2
8	9628 "	Clamp - Trunnion	4
9	9919A	Swivel - Stabilizer	1
10	0635A	Assy. Stabilizer Rod	1
11	10460A	Spring - 3" O.D. x 7" Long	2
12	10872	Washer - Cut 1-3/8" PL	3
13	9892	Swivel	1
14	10606	Fitting - Grease 1/8" NPT Threaded	2
15	11279	Nut - Hex 1-3/8" NG Slotted	1
16	10910	Pin - Roll 5/16" x 2-1/4"	1
18	12075	Bolt - Hex 3/4" x 5-1/2" NC, PLT, Gr. 5	2
19	20534	Assy. Main Frame	1
20	10042	Bolt - Machine 5/8" x 6" NC, PL, Gr. 5	1
21	12075	Bolt - Hex 3/4" x 5-1/2" NC, PLT, Gr. 5	8
22	10300	Nut - Lock 3/4" Lock Nut	8
23	102365	Strap - 3/4" x 2-1/2" x 8-1/8" Long	4
24	10765	Bolt - Hex 3/8" x 2-1/2" NC, PL, Gr. 5	2
25	10509	Nut - Lock 3/8" NC, PL	2
26	9209	Pin - Retainer 1-1/2" Dia. X 5-1/4" Long	2
27	20535	Assy. Rockshaft	1
28	10617	Cotter Key - 1/4" x 3"	2
29	102366	Assy. Transport Pin - 3/4" Dia. X 2-1/2 " Long	2
30	102362	Assy. Transport Strap	2
31	10317	Klik Pin 1/4"	2
33	11081	Fitting - Grease	2
34	9270	Bushing - Bronze (Not Shown) 1-3/4" O.D. x 1-1/2" I.D. x 2" Long	2
35	10915	Spindle	2

**AMCO
C41 & D41 SERIES
HUB & WHEEL**

<u>Ref. No.</u>	<u>Part No.</u>	<u>Description</u>	<u>No. Req'd.</u>
1	11017	Grease Seal	1
2	10353	Cone - Inner Timken #LM48548	1
3	11644	Hub wit 2 cups & 6 lug bolts, nut	1
3	10352	Cup - Inner (LM48510)	1
3	10293	Cup - Outer (LM67010)	1
3	12442	Hub - Bolt 1/2" x 1-13/16" NF	6
3	11046	Hub - Nut 1/2" NF	6
4	10295	Cone - Outer Timken #LM67048	1
5	10263	Spindle Washer 7/8"	1
6	10264	Spindle Nut 7/8" NF	1
7	10291	Cotter Pin 5/32" x 1-1/4"	1
8	10356	Hub - Cap	1
9	10484	Wheel 14 x 6 - 6 Hole	1
	12074	Tire 9.5L x 14 - 8 Ply Tubless (Not Shown)	1

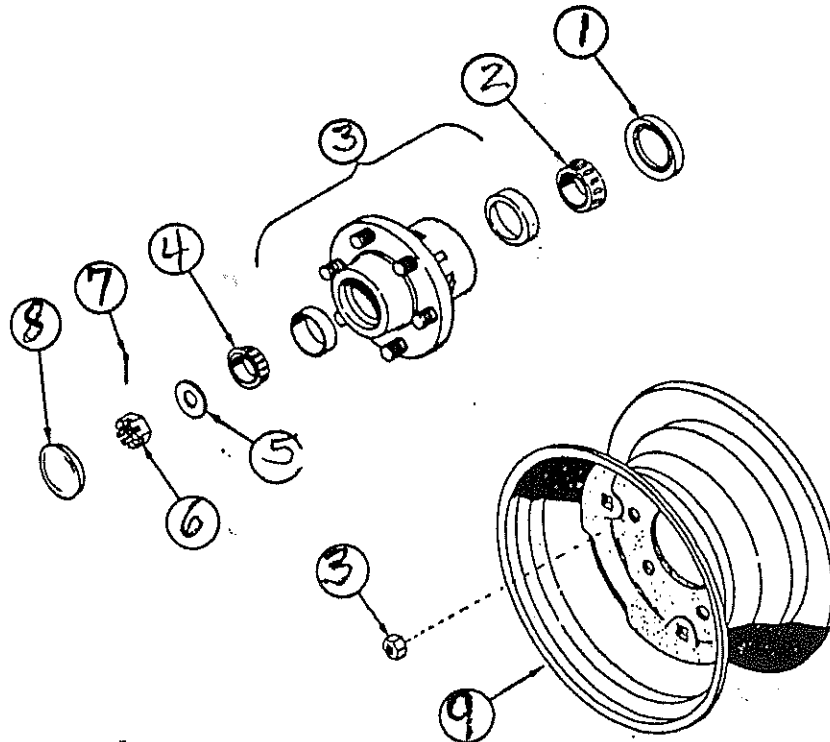

AMCO
C41 & D41 SERIES
3 x 8 HYDRAULIC CYLINDER (OPTIONAL)

<u>Ref. No.</u>	<u>Part No.</u>	<u>Description</u>	<u>No. Req'd.</u>
1	12256	Rod	1
2	12257	Barrel	1
3	12258	Base Clevis	1
4	12259	Gland	1
5	12260	Piston	1
6	12261	Nut - Self Locking	1
7	12262	Rod Clevis	1
8	12263	Rod - Tie	4
9	12264	Hex Nut - Tie Rod	8
17	12265	Assy. Pin	2
18	12267	Control Stroke	1
19	12255	Kit - Seal Repair	1
	12268	Hydraulic Cylinder 3 x 8 w/ Stroke Control Lion 2500 PSI	1

Note: Items #10-16 Sold in Seal Kit Only.

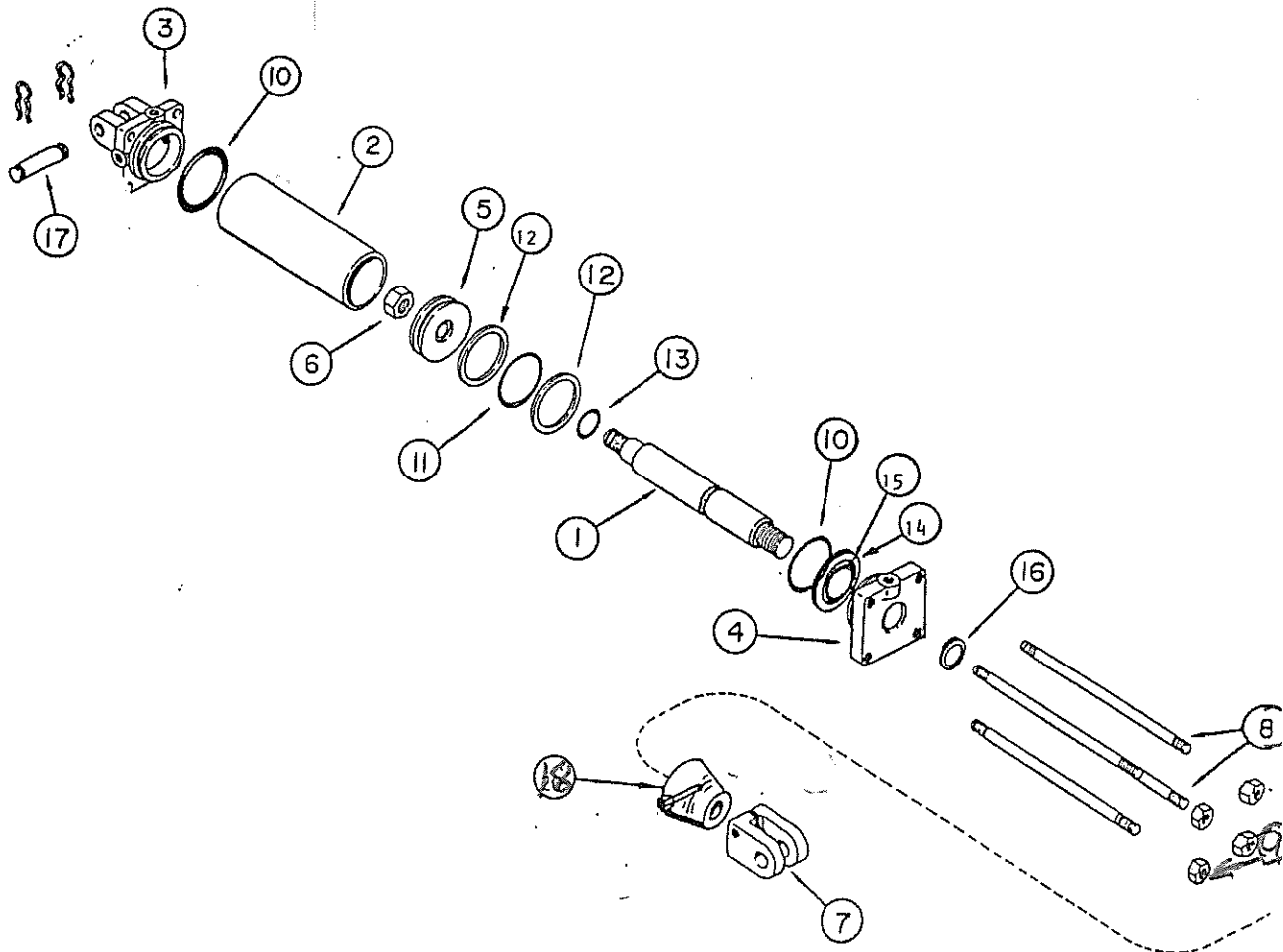

**AMCO
C41 & D41 SERIES
OPTIONAL FEATHERING BLADE**

<u>Ref. No.</u>	<u>Part No.</u>	<u>Description</u>	<u>No. Req'd.</u>
1	7673	Spacer - Blade	2
2	3267	Blade 16" Dia. X 7 Ga. Plain	1
3	7801	Cap - Blade	2
4	10189	Bolt - Hex 7/8" x 3" NC	2
5	10832	Cut Washer 1/2" PL	2
6	10396	Lock Nut 7/8" NC, PL	2
7	10238	Bolt - Carriage 1/2" x 2-1/2" NC, PL	8
8	10395	Nut - Lock 1/2" NC, PL	10
9	0788	Scraper - RH	1
9	0789	Scraper - LH	1
10	10870	Bolt - Carriage 1/2" x 1-1/2" NC, PL	2

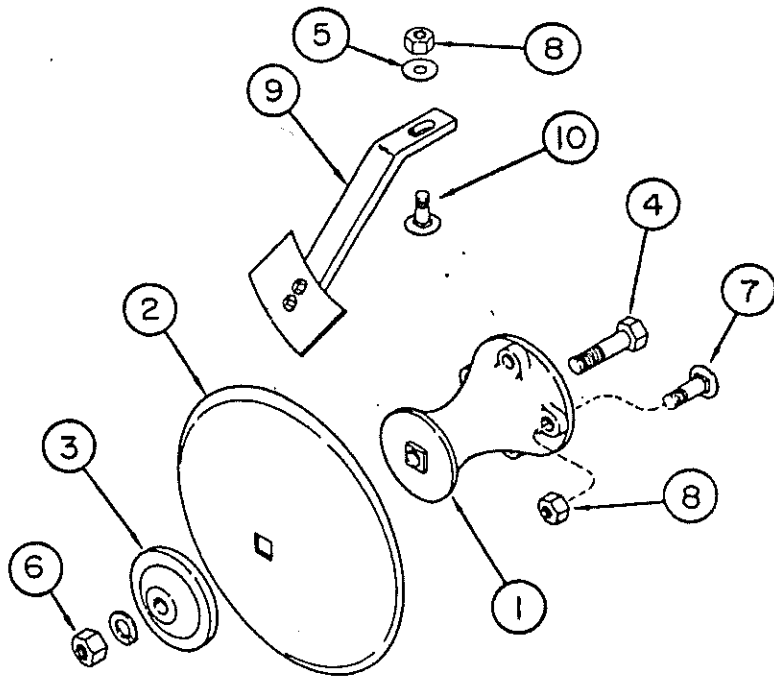

FEATHERING BLADE

AMCO						
C41						
FRONT GANG & FRAME						
<u>Ref. No.</u>	<u>Part No.</u>	<u>Description</u>	<u>No. Req'd.</u>			
			<u>20 BI</u>	<u>22 BI</u>	<u>24 BI</u>	<u>26 BI</u>
1	102344	Gang Frame 4" x 3" x 1/4 WT - 64" Long	1			
1	102389	Gang Frame 4" x 3" x 1/4 WT - 71-1/4" Long		1		
1	12390	Gang Frame 4" x 3" x 1/4 WT - 78-1/2" Long			1	
1	102391	Gang Frame 4" x 3" x 1/4 wt - 85-3/4" Long				1
2	20370	Bearing Riser - RH	3	3	3	3
2	20371	Bearing Riser - LH				
3	7205	U-Bolt	3	3	3	3
4	10300	3/4" NC, PLT, Lock Nut	6	6	6	6
5	11647	Flange Lock Nut 5/8" NC, PLT	3	3	3	3
6	10135	Carriage Screw 5/8" x 1-3/4" NC, PLT, Gr. 5	3	3	3	3
7	10068	Carriage Screw 7/16" x 1-1/2" NC, PLT, Gr. 2	9	9	9	9
8	10619	Lock Washer 7/16" PLT	9	9	9	9
9	10618	Hex Nut 7/16" NC, PLT	9	9	9	9
10	11035	Nut Gang Bolt - 1-1/8" NC Hvy	2	2	2	2
11	2116	Lock Plate	1	1	1	1
12	2030	End Gang Washer	1	1	1	1
13	3254	20 x 7 Ga. C.O. Blade - 1-11/64	10	11	12	13
13	3262	20 x 7 Ga. PL Blade - 1-11/64	10	11	12	13
13	3271	22 x 7Ga. C.O. Blade - 1-11/64	10	11	12	13
13	3269	22 x 7 Ga. PL Blade - 1-11/64	10	11	12	13
13	11587	22 x 1/4" C.O. Blade - 1-11/64	10	11	12	13
13	11586	22 x 1/4" PL Blade - 1-11/64	10	11	12	13
15	17024	End Bell - Large	3	3	3	3
17	102396	Sleeve - Insert	3	3	3	3
18	12071	Bearing ST491A	3	3	3	3
20	17026	End Bell - Small	3	3	3	3
23	9830	Spacer Spool	6	7	8	9
24	3412A	Bumper Washer	1	1	1	1
26	100251	Gang Bolt 1-1/8" Sq 10 BL-70" Long	1			
26	100252	Gang Bolt 1-1/8" Sq 11 BL-77-3/8" Long		1		
26	102394	Gang Bolt 1-1/8" Sq. 12 BL -86-1/4" Long			1	
26	102395	Gang Bolt 1-1/8" Sq 13 BL - 91" Long				1
27	9961	Scraper Bar - 68-3/4" Long	1			
27	9962	Scraper Bar - 76" Long		1		
27	101602	Scraper Bar - 83-1/4" Long			1	
27	102173	Scraper Bar - 90-1/2" Long				1
28	0788	Assy. Scraper - RH	9	10	11	12
	100270	Scraper Blade	1	1	1	1
	100271	Scraper Leg	1	1	1	1
	10395	Lock Nut 1/2" NC, PLT	2	2	2	2
	11652	1/2 x 1-1/4 NC, PLT, Gr. 5 - Hex Bolt	2	2	2	2
29	00789	Scraper - LH				
30	10870	Carriage Screw - 1/2 x 1-1/2 NC, PLT, Gr. 5	9	10	11	12
31	9906	1/4 x 4 Filler Plate (Not Shown)	Order	as	Required	

AMCO						
C41						
FRONT GANG & FRAME						
<u>Ref. No.</u>	<u>Part No.</u>	<u>Description</u>	<u>No. Req'd.</u>			
			<u>20 BI</u>	<u>22 BI</u>	<u>24 BI</u>	<u>26 BI</u>
1	102344	Gang Frame 4" x 3" x 1/4 WT - 64" Long	1			
1	102389	Gang Frame 4" x 3" x 1/4 WT - 71-1/4" Long		1		
1	12390	Gang Frame 4" x 3" x 1/4 WT - 78-1/2" Long			1	
1	102391	Gang Frame 4" x 3" x 1/4 wt - 85-3/4" Long				1
2	20370	Bearing Riser - RH	3	3	3	3
2	20371	Bearing Riser - LH				
3	7205	U-Bolt	3	3	3	3
4	10300	3/4" NC, PLT, Lock Nut	6	6	6	6
5	11647	Flange Lock Nut 5/8" NC, PLT	3	3	3	3
6	10135	Carriage Screw 5/8" x 1-3/4" NC, PLT, Gr. 5	3	3	3	3
7	10068	Carriage Screw 7/16" x 1-1/2" NC, PLT, Gr. 2	9	9	9	9
8	10619	Lock Washer 7/16" PLT	9	9	9	9
9	10618	Hex Nut 7/16" NC, PLT	9	9	9	9
10	11035	Nut Gang Bolt - 1-1/8" NC Hvy	2	2	2	2
11	2116	Lock Plate	1	1	1	1
12	2030	End Gang Washer	1	1	1	1
13	3254	20 x 7 Ga. C.O. Blade - 1-11/64	10	11	12	13
13	3262	20 x 7 Ga. PL Blade - 1-11/64	10	11	12	13
13	3271	22 x 7Ga. C.O. Blade - 1-11/64	10	11	12	13
13	3269	22 x 7 Ga. PL Blade - 1-11/64	10	11	12	13
13	11587	22 x 1/4" C.O. Blade - 1-11/64	10	11	12	13
13	11586	22 x 1/4" PL Blade - 1-11/64	10	11	12	13
15	17024	End Bell - Large	3	3	3	3
17	102396	Sleeve - Insert	3	3	3	3
18	12071	Bearing ST491A	3	3	3	3
20	17026	End Bell - Small	3	3	3	3
23	9830	Spacer Spool	6	7	8	9
24	3412A	Bumper Washer	1	1	1	1
26	100251	Gang Bolt 1-1/8" Sq 10 BL-70" Long	1			
26	100252	Gang Bolt 1-1/8" Sq 11 BL-77-3/8" Long		1		
26	102394	Gang Bolt 1-1/8" Sq. 12 BL -86-1/4" Long			1	
26	102395	Gang Bolt 1-1/8" Sq 13 BL - 91" Long				1
27	9961	Scraper Bar - 68-3/4" Long	1			
27	9962	Scraper Bar - 76" Long		1		
27	101602	Scraper Bar - 83-1/4" Long			1	
27	102173	Scraper Bar - 90-1/2" Long				1
28	0788	Assy. Scraper - RH	9	10	11	12
	100270	Scraper Blade	1	1	1	1
	100271	Scraper Leg	1	1	1	1
	10395	Lock Nut 1/2" NC, PLT	2	2	2	2
	11652	1/2 x 1-1/4 NC, PLT, Gr. 5 - Hex Bolt	2	2	2	2
29	00789	Scraper - LH				
30	10870	Carriage Screw -1/2 x 1-1/2 NC, PLT, Gr. 5	9	10	11	12
31	9906	1/4 x 4 Filler Plate (Not Shown)	Order	as	Required	

C41
GANG & FRAME REAR

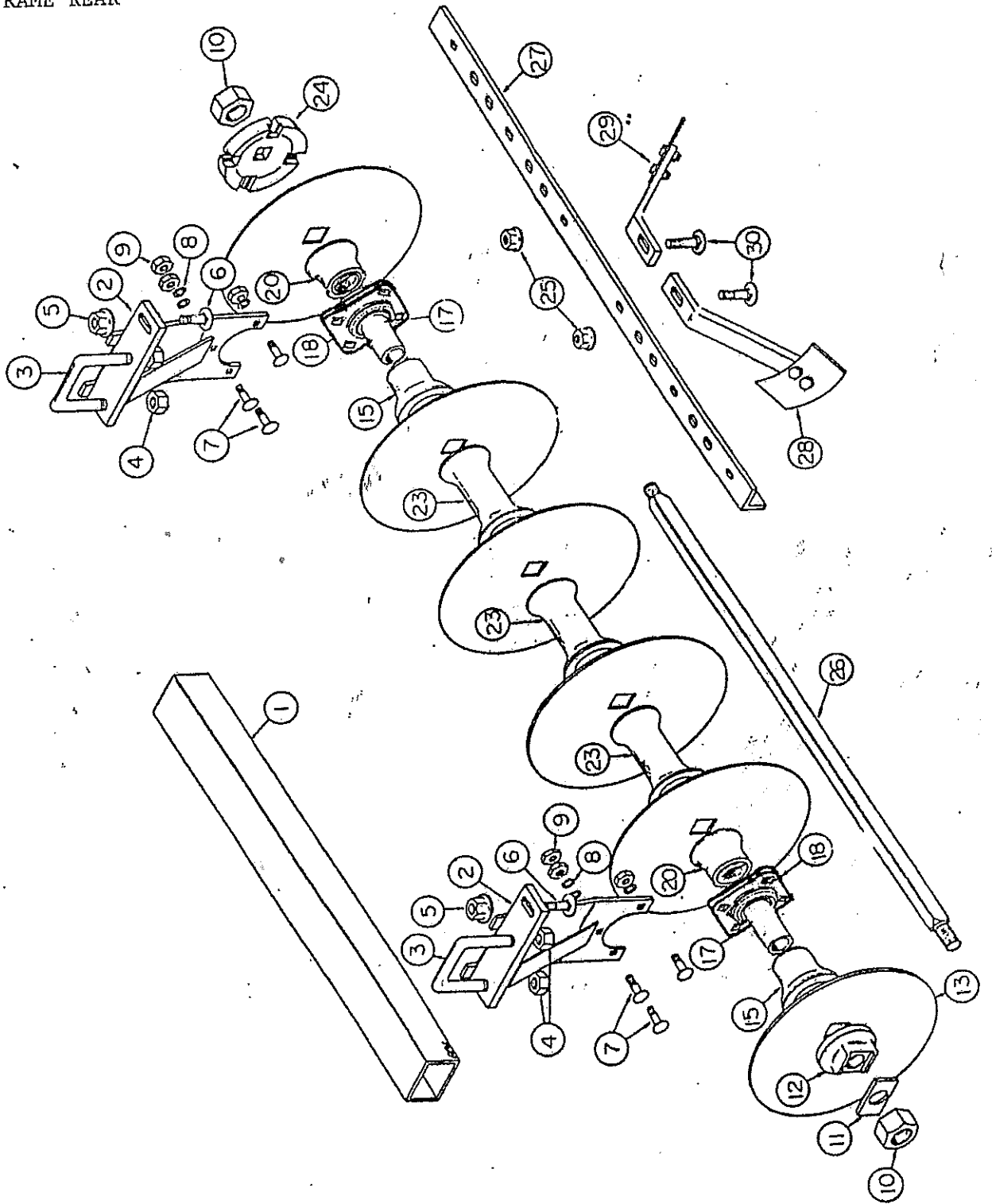

**AMCO
C41
REAR GANG & FRAME**

<u>Ref. No.</u>	<u>Part No.</u>	<u>Description</u>	<u>No. Req'd.</u>			
			<u>20 BI</u>	<u>22 BI</u>	<u>24 BI</u>	<u>26 BI</u>
1	102344	Gang Frame 4" x 3" x 1/4 WT - 64" Long	1			
1	102389	Gang Frame 4" x 3" x 1/4 WT - 71-1/4" Long		1		
1	12390	Gang Frame 4" x 3" x 1/4 WT - 78-1/2" Long			1	
1	102391	Gang Frame 4" x 3" x 1/4 wt - 85-3/4" Long				1
2	20370	Bearing Riser - RH	3	3	3	3
2	20371	Bearing Riser - LH				
3	7205	U-Bolt	3	3	3	3
4	10300	3/4" NC, PLT, Lock Nut	6	6	6	6
5	11647	Flange Lock Nut 5/8" NC, PLT	3	3	3	3
6	10135	Carriage Screw 5/8" x 1-3/4" NC, PLT, Gr. 5	3	3	3	3
7	10068	Carriage Screw 7/16" x 1-1/2" NC, PLT, Gr. 2	9	9	9	9
8	10619	Lock Washer 7/16" PLT	9	9	9	9
9	10618	Hex Nut 7/16" NC, PLT	9	9	9	9
10	11035	Nut Gang Bolt - 1-1/8" NC Hvy	2	2	2	2
11	2116	Lock Plate	1	1	1	1
12	2030	End Gang Washer	1	1	1	1
13	3254	20 x 7 Ga. C.O. Blade - 1-11/64	10	11	12	13
13	3262	20 x 7 Ga. PL Blade - 1-11/64	10	11	12	13
13	3271	22 x 7Ga. C.O. Blade - 1-11/64	10	11	12	13
13	3269	22 x 7 Ga. PL Blade - 1-11/64	10	11	12	13
13	11587	22 x 1/4" C.O. Blade - 1-11/64	10	11	12	13
13	11586	22 x 1/4" PL Blade - 1-11/64	10	11	12	13
15	17024	End Bell - Large	3	3	3	3
17	102396	Sleeve - Insert	3	3	3	3
18	12071	Bearing ST491A	3	3	3	3
20	17026	End Bell - Small	3	3	3	3
23	9830	Spacer Spool	6	7	8	9
24	3412A	Bumper Washer	1	1	1	1
26	100251	Gang Bolt 1-1/8" Sq 10 BL-70" Long	1			
26	100252	Gang Bolt 1-1/8" Sq 11 BL-77-3/8" Long		1		
26	102394	Gang Bolt 1-1/8" Sq. 12 BL -86-1/4" Long			1	
26	102395	Gang Bolt 1-1/8" Sq 13 BL - 91" Long				1
27	9961	Scraper Bar - 68-3/4" Long	1			
27	9962	Scraper Bar - 76" Long		1		
27	101602	Scraper Bar - 83-1/4" Long			1	
27	102173	Scraper Bar - 90-1/2" Long				1
28	0788	Assy. Scraper - RH	9	10	11	12
	100270	Scraper Blade	1	1	1	1
	100271	Scraper Leg	1	1	1	1
	10395	Lock Nut 1/2" NC, PLT	2	2	2	2
	11652	1/2 x 1-1/4 NC, PLT, Gr. 5 - Hex Bolt	2	2	2	2
29	00789	Scraper - LH				
30	10870	Carriage Screw -1/2 x 1-1/2 NC, PLT, Gr. 5	9	10	11	12
31	9906	1/4 x 4 Filler Plate (Not Shown)	Order	as	Required	

D 41
GANG & FRAME FRONT

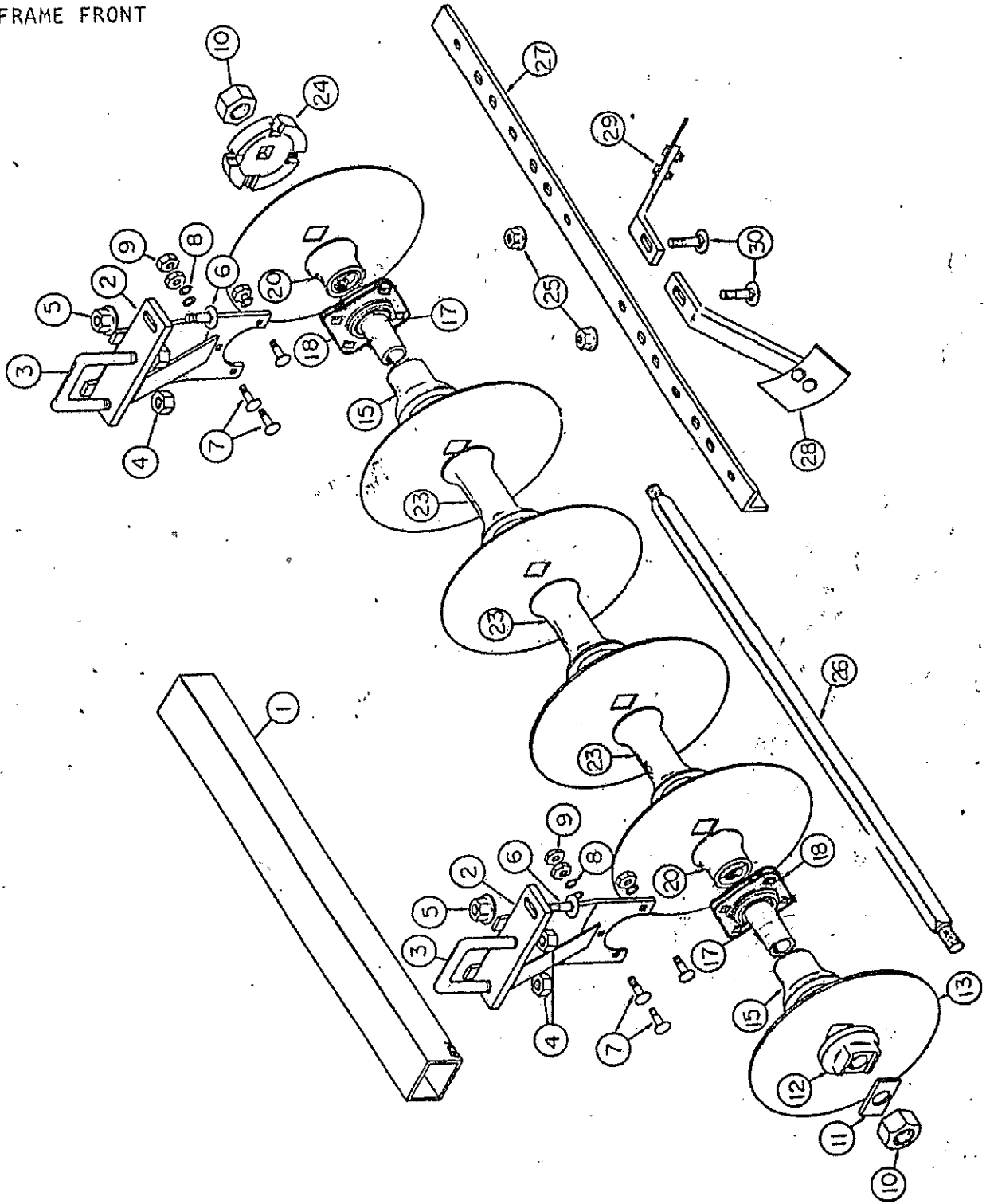

AMCO								
D41								
FRONT GANG & FRAME								
<u>Ref. No.</u>	<u>Part No.</u>	<u>Description</u>	<u>No.</u>		<u>Req'd.</u>			
			<u>16BL</u>	<u>18 BL</u>	<u>20 BL</u>	<u>22BL</u>	<u>24BL</u>	<u>26 BL</u>
1	102344	Gang Frame 4 x 3 x 1/4 WT - 64" Long	1					
1	102345	Gang Frame 4 x 3 x 1/4 WT - 73-1/4" Long		1				
1	102346	Gang Frame 4 x 3 x 1/4 WT - 82-1/2" Long			1			
1	102384	Gang Frame 4 x 3 x 1/4 WT - 91-3/4" Long				1		
1	102385	Gang Frame 4 x 3 x 1/4 WT - 101" Long					1	
1	102594	Gang Frame 4 x 3 x 1/4 WT - 110" Long						1
2	20370	Bearing Riser - RH	3	3	3	3	4	3
2	20371	Bearing Riser - LH						3
3	7205	U-Bolt	3	3	3	3	4	3
4	10300	3/4" NC, PLT, Lock Nut	6	6	6	6	8	6
5	11647	Flange Lock Nut 5/8" NC, PLT	3	3	3	3	4	3
6	10135	Carriage Screw 5/8" x 1-3/4" NC, PLT, Gr. 5	3	3	3	3	4	3
7	10068	Carriage Screw 5/16" x 1-1/2" NC, PLT, Gr. 2	9	9	9	9	12	9
8	10619	Lock Washer 7/16" PLT	9	9	9	9	12	9
9	10618	Hex Nut 7/16" NC, PLT	9	9	9	9	12	9
10	11035	Nut Gang Bolt 1-1/8" NC HVY	2	2	2	2	4	9
11	2116	Lock Plate	1	1	1	1	2	1
12	2030	End Gang Washer	1	1	1	1	2	1
13	3254	20" x 7 Ga. C.O. Blade - 1-11/64	8	9	10	11	12	13
13	3262	20" x 7 Ga. Plain Blade - 1-11/64	8	9	10	11	12	13
13	3271	22" x 7 Ga. C.O. Blade - 1-11/64	8	9	10	11	12	13
13	3269	22" x 7 Ga. Plain Blade - 1-11/64	8	9	10	11	12	13
13	12332	22" x 1/4" C.O. Blade - 1-11/64	8	9	10	11	12	13
13	12333	22" x 1/4" Plain Blade - 1-11/64	8	9	10	11	12	13
15	17024	End Bell - Large	3	3	3	3	4	3
17	102369	Sleeve - Insert	3	3	3	3	4	3
18	12071	Bearing ST491A	3	3	3	3	4	3
20	17025	End Bell - Small	3	3	3	3	4	3
23	6165	Spacer Spool	4	5	6	7	6	9
24	3412A	Bumper Washer	1	1	1	1	2	1
25	11646	Flange Lock Nut 1/2" NC, PLT, Gr. G	7	8	9	10	11	10
26	100244	Gang Bolt 1-1/8" Sq. 8 BL - 69-1/16"	1					
26	100245	Gang Bolt 1-1/8" Sq. 9 BL - 78-1/4"		1				
26	102379	Gang Bolt 1-1/8" Sq. 10BL - 86-11/16"			1			
26	102387	Gang Bolt 1-1/8" Sq. 11 BL - 95-5/8"				1		
26	102388	Gang Bolt 1-1/8" Sq. 6 BL - 50-1/8"					2	
26	102177	Gang Bolt 1-1/8" Sq. 13 BL - 114-3/8" Long						1
27	9550	Scraper Bar 70-1/16" Long	1					
27	9551	Scraper Bar 79-1/4" Long		1				
27	100367	Scraper Bar 88-7/16" Long			1			
27	100534	Scraper Bar 97-5/8" Long				1		
27	100366	Scraper Bar 106-13/16" Long					1	
27	100446	Scraper Bar 116" Long 2 x 2 x 3/8						1
28	0788	Assy. Scraper - RH	7	8	9	10	11	12
	100270	Scraper Blade	1	1	1	1	1	1
	100271	Scraper Leg	1	1	1	1	1	1
	10395	Lock Nut 1/2" NC, PLT	2	2	2	2	2	2
	11652	1/2 x 1-1/4 NC, PLT, Gr. 5 - Hex Bolt	2	2	2	2	2	2
	00789	Scraper - LH						
	10870	Carriage Screw -1/2 x 1-1/2 NC, PLT, Gr. 5	7	8	9	10	11	12
	9906	1/4 x 4 Filler Plate (Not Shown)	Order	as	Required			

D41
GANG & FRAME Rear

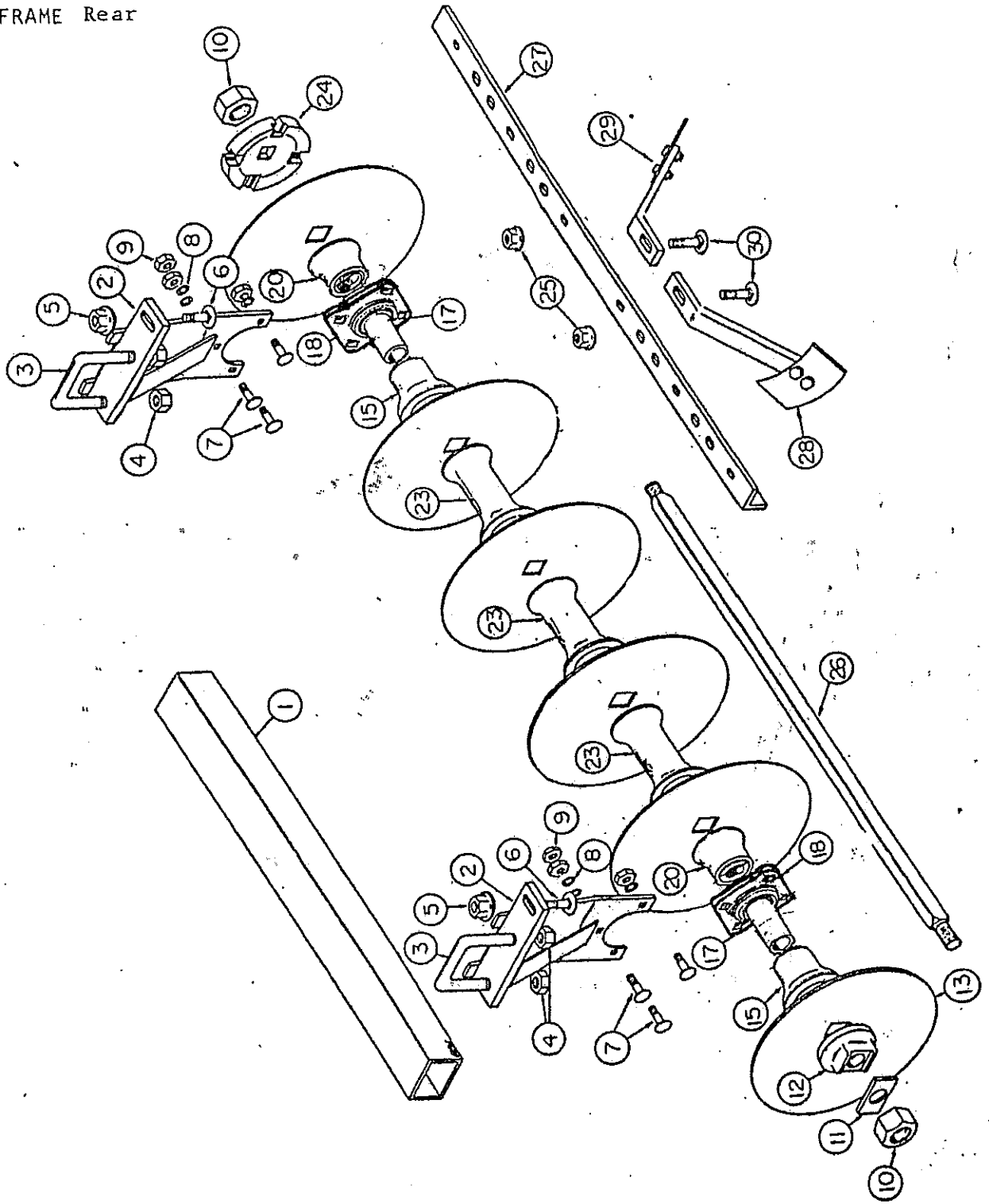

**AMCO
D41
REAR GANG & FRAME**

Ref. No.	Part No.	Description	No. Req'd.					
			16BL	18 BL	20 BL	22BL	24BL	26 BL
1	102344	Gang Frame 4 x 3 x 1/4 WT - 64" Long	1					
1	102345	Gang Frame 4 x 3 x 1/4 WT - 73-1/4" Long		1				
1	102346	Gang Frame 4 x 3 x 1/4 WT - 82-1/2" Long			1			
1	102384	Gang Frame 4 x 3 x 1/4 WT - 91-3/4" Long				1		
1	102385	Gang Frame 4 x 3 x 1/4 WT - 101" Long					1	
1	102594	Gang Frame 4 x 3 x 1/4 WT - 110" Long						1
2	20370	Bearing Riser - RH	3	3	3	3	4	3
2	20371	Bearing Riser - LH						3
3	7205	U-Bolt	3	3	3	3	4	3
4	10300	3/4" NC, PLT, Lock Nut	6	6	6	6	8	6
5	11647	Flange Lock Nut 5/8" NC, PLT	3	3	3	3	4	3
6	10135	Carriage Screw 5/8" x 1-3/4" NC, PLT, Gr. 5	3	3	3	3	4	3
7	10068	Carriage Screw 5/16" x 1-1/2" NC, PLT, Gr. 2	9	9	9	9	12	9
8	10619	Lock Washer 7/16" PLT	9	9	9	9	12	9
9	10618	Hex Nut 7/16" NC, PLT	9	9	9	9	12	9
10	11035	Nut Gang Bolt 1-1/8" NC HVY	2	2	2	2	4	9
11	2116	Lock Plate	1	1	1	1	2	1
12	2030	End Gang Washer	1	1	1	1	2	1
13	3254	20" x 7 Ga. C.O. Blade - 1-11/64	8	9	10	11	12	13
13	3262	20" x 7 Ga. Plain Blade - 1-11/64	8	9	10	11	12	13
13	3271	22" x 7 Ga. C.O. Blade - 1-11/64	8	9	10	11	12	13
13	3269	22" x 7 Ga. Plain Blade - 1-11/64	8	9	10	11	12	13
13	12332	22" x 1/4" C.O. Blade - 1-11/64	8	9	10	11	12	13
13	12333	22" x 1/4" Plain Blade - 1-11/64	8	9	10	11	12	13
15	17024	End Bell - Large	3	3	3	3	3	3
17	102369	Sleeve - Insert	3	3	3	3	4	3
18	12071	Bearing ST491A	3	3	3	3	4	3
20	17025	End Bell - Small	3	3	3	3	4	3
23	6165	Spacer Spool	4	5	6	7	6	9
24	3412A	Bumper Washer	1	1	1	1	2	1
25	11646	Flange Lock Nut 1/2" NC, PLT, Gr. G	7	8	9	10	11	10
26	100244	Gang Bolt 1-1/8" Sq. 8 BL - 69-1/16"	1					
26	100245	Gang Bolt 1-1/8" Sq. 9 BL - 78-1/4"		1				
26	102379	Gang Bolt 1-1/8" Sq. 10BL - 86-11/16"			1			
26	102387	Gang Bolt 1-1/8" Sq. 11 BL - 95-5/8"				1		
26	102388	Gang Bolt 1-1/8" Sq. 6 BL - 50-1/8"					2	
26	102177	Gang Bolt 1-1/8" Sq. 13 BL - 114-3/8" Long						1
27	9550	Scraper Bar 70-1/16" Long	1					
27	9551	Scraper Bar 79-1/4" Long		1				
27	100367	Scraper Bar 88-7/16" Long			1			
27	100534	Scraper Bar 97-5/8" Long				1		
27	100366	Scraper Bar 106-13/16" Long					1	
27	100446	Scraper Bar 116" Long 2 x 2 x 3/8						1
28	0788	Assy. Scraper - RH						
	100270	Scraper Blade	1	1	1	1	1	1
	100271	Scraper Leg	1	1	1	1	1	1
	10395	Lock Nut 1/2" NC, PLT	2	2	2	2	2	2
	11652	1/2 x 1-1/4 NC, PLT, Gr. 5 - Hex Bolt	2	2	2	2	2	2
29	00789	Scraper - LH	7	8	9	10	11	11
	10870	Carriage Screw -1/2 x 1-1/2 NC, PLT, Gr. 5	7	8	9	10	11	11
	9906	1/4 x 4 Filler Plate (Not Shown)	Order	as	Required			

DECALS

①



②

! WARNING

1. BEFORE OPERATING - STUDY OPERATORS MANUAL SAFETY MESSAGES AND SAFE OPERATING PROCEDURES, READ SAFETY SIGNS ON THIS MACHINE.
2. TRANSPORT ON PUBLIC ROADS - OBSERVE FEDERAL, STATE AND LOCAL REGULATIONS; DISPLAY SMV EMBLEM; ATTACH PROPER STRENGTH SAFETY CHAIN TO TOWED IMPLEMENT; AND LIMIT MAXIMUM SPEED TO 20mph (32 km/h).
3. LOWER OR BLOCK ALL ELEVATED COMPONENTS BEFORE SERVICING OR LEAVING THIS MACHINE.

③

MAINTENANCE INSTRUCTIONS

1. Keep all bolts tight. Check after first 50 hours or one week's operation. Visually inspect all bolts daily.
2. Keep wheel bearings properly adjusted. Clean and repack each season or every 300 hours. Replace all worn or damaged parts when repairing.
3. Keep gang bolts tight! Tighten after first day's operation. Do not run with loose disk blades. If gang bolts have been operated in a loose condition, retighten, then tighten again after 30 minutes use, again after 4 to 5 hours, and again after 8 to 10 hours.
4. Grease gang bearings daily with a hand grease gun and a good grade of clean, number 2, lithium soap base grease. Always wipe fittings clean before greasing. Apply grease until old or dirty grease is purged from bearings. Avoid high-pressure greasing.
5. Inspect for damaged or misaligned parts if gangs do not turn smoothly by hand. Bearings will fail prematurely if operated with misaligned or damaged gang parts. If a gang is operated for one or more hours following a bearing failure replace all bearings on the gang.

Refer to the operator's manual for other important maintenance instructions.

11716

<u>Ref. No.</u>	<u>Part No.</u>	<u>Description</u>	<u>No. Req'd.</u>
AMCO			
C-41 & D-41			
DECALS			
1	11465	Decal - AMCO	3
2	11741	Decal - Warning	1
3	11716	Decal - Maintenance	1
	12540	Reflector - Orange	2
	12541	Reflector - Red	2

SAFETY SUGGESTIONS

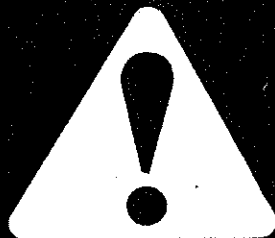

THIS SAFETY ALERT SYMBOL INDICATES IMPORTANT SAFETY MESSAGES IN THIS MANUAL. WHEN YOU SEE THIS SYMBOL, CAREFULLY READ THE MESSAGE THAT FOLLOWS AND BE ALERT TO THE POSSIBILITY OF PERSONAL INJURY.



CAUTION *Never stand between tractor and disk harrow when hitching unless all controls are in neutral and the brakes are locked.*



CAUTION *Park or block the disk harrow so it will not roll when disconnected from the tractor drawbar.*



CAUTION *When working on disk harrows, care should be exercised in handling or tightening bolts near disk blades to avoid injury.*



CAUTION *Always secure for transport by using the lock pin and wing lock pins.*



CAUTION *Never clean, adjust or lubricate a disk harrow that is in motion.*



CAUTION *When transporting machinery over public roads, comply with your local and state laws regarding length, width and lighting.*



CAUTION *When trailing the harrow over public roads, the SMV Emblem must be used, for protection of tractor and motor vehicle operators.*









CAUTION *When transporting farm implements on public roads after dusk it is the responsibility of the operator to provide lighting and reflectors on the rear of the implement in accordance with your state law.*



CAUTION *All hydraulically or mechanically elevated operating components must be blocked to prevent accidental lowering or must be lowered to the ground when making adjustments or when the equipment is idle.*

GENERAL TORQUE SPECIFICATION TABLE

ALL BOLTS SHOULD BE TIGHTENED TO THE
RECOMMENDED TORQUES SHOWN IN THE
"GENERAL TORQUE SPECIFICATION TABLE"

GENERAL TORQUE SPECIFICATION TABLE							
USE THE FOLLOWING TORQUES WHEN SPECIAL TORQUES ARE NOT GIVEN							
<p>Note: These values apply to fasteners as received from supplier, dry, or when lubricated with normal engine oil. They do not apply if special graphited or moly-disulphide greases or other extreme pressure lubricants are used. This applies to both UNF and UNC threads.</p>							
SAE Grade No.		2		5		8 *	
Bolt head identification marks as per grade NOTE: Manufacturing Marks Will Vary				  		  	
		Torque		Torque		Torque	
Bolt Size		Foot Pounds		Foot Pounds		Foot Pounds	
Inches	Millimeters	Min	Max	Min	Max	Min	Max
1/4	6.35	5	6	9	11	12	15
5/16	7.94	10	12	17	20 5	24	29
3/8	9.53	20	23	35	42	45	54
7/16	11 11	30	35	54	64	70	84
1/2	12 70	45	52	80	96	110	132
9/16	14 29	65	75	110	132	160	192
5/8	15 88	95	105	150	180	220	264
3/4	19 05	150	185	270	324	380	456
7/8	22.23	160	200	400	480	600	720
1	25.40	250	300	580	696	900	1080
1-1/8	25.58			800	880	1280	1440
1-1/4	31.75			1120	1240	1820	2000
1-3/8	34 93			1460	1680	2380	2720
1-1/2	38 10			1940	2200	3160	3560

* Thick nuts must be used with Grade 8 bolts

assembly instructions

AMCO D-41 & C-41 HARROW

The AMCO D41 series disk harrow is shipped from the factory with maximum pre-assembly in the following bundles:

1. Main frame, rockshaft, cross tongue, and pull tongue.
2. Two gang and frame bundles with scrapers and scraper bars installed.
3. Two 14X6 -6 bolt wheels.

ASSEMBLY PROCEDURE:

1. Place all bundles where they will be convenient. Arrange loose parts so they may be readily seen when needed. To insure good alignment of units and parts, insert all bolts leaving the nuts slightly loose. Tighten the nuts evenly to prevent misalignment, distortion or binding. Be sure all bolts are tight, all cotter pins properly spread and all pins properly inserted.
2. Select a clean level area for assembly. Place the main frame on sturdy stands.
3. The cross tongue should be located in the set of holes on the main frame that will best match the pull tongue to the tractor drawbar height.



CAUTION Use sturdy stands to prevent frame from falling.

4. Attach stabilizer to the hitch control bracket and hitch on cross tongue.
5. Mount tires and tubes on 14X6 wheels. Inflate tires. 9.5L x 14 or 6.70 x14 tires are recommended. Bolt the wheels to the hubs.
6. Install a 3 x 8 hydraulic cylinder with stroke control (optional) to the harrow. Connect hydraulic hoses from the cylinder to the tractor. Attach the pull tongue to the tractor drawbar. Optional- attach ratchet jack in place of hyd. cyl. Raise the harrow up on the wheels by activating the hydraulic cylinder or with ratchet jack.

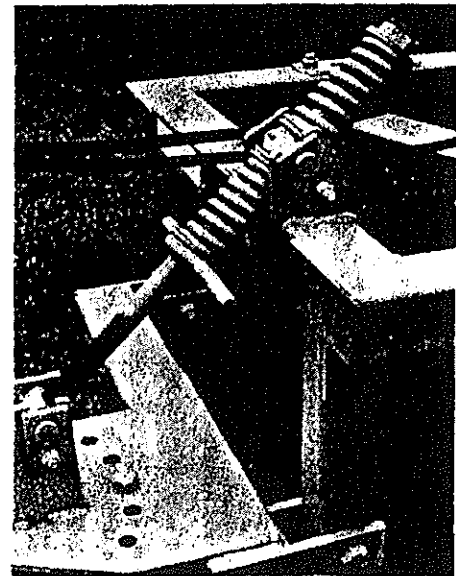

CAUTION When working on disk harrows care should be exercised in handling or tightening bolts near disk blades to avoid injury. All hydraulically or mechanically elevated components must be blocked or lowered to prevent accidents when servicing the harrow.

10. Remove gang clamp from the main frame. Attach the gang assemblies to the main frame. Secure them with clamp plates and 3/4" dia. bolts. Convex end of the gang faces to the left on the front gang and to the right on the rear gang.
11. Tighten bolts snug but not tight. For proper placement of the gang frame on the main frame, refer to the chart and drawing at the end of these instructions. Dimension "A" is measured from the outside of the main frame, along the center line of the gang frame to the inside of the "U" bolt.
12. Check and tighten all bolts. Be sure all cotter pins are properly spread and all pins in place. Check the gangs to see that they rotate freely.
13. Be sure that the harrow is properly lubricated.
14. Adjust the harrow for front to rear leveling.

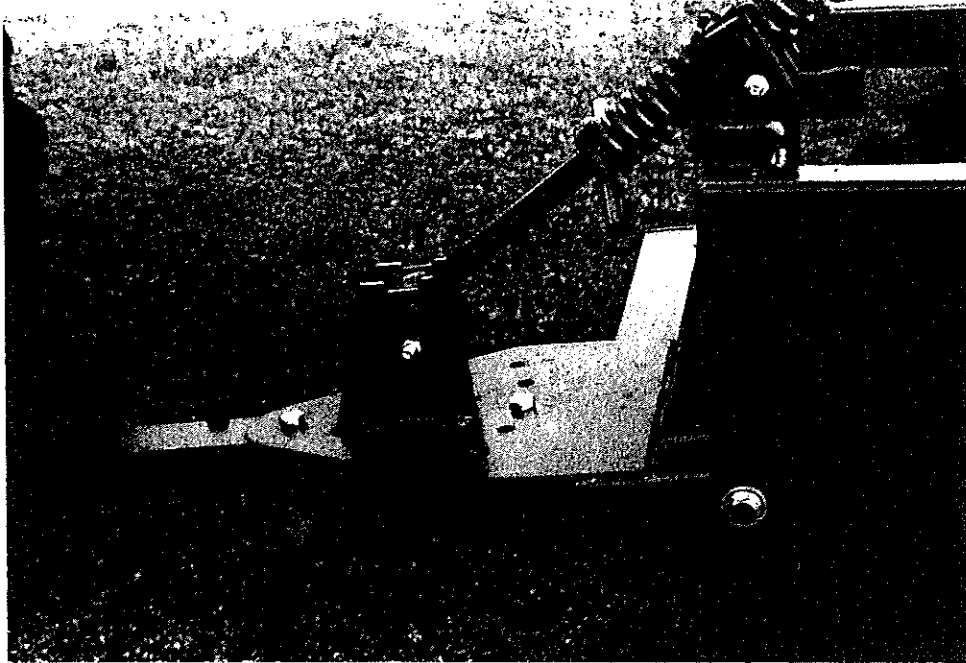

Model	Measurement "A"
D41 - 16 Blade	7-3/4
D41 - 18 Blade	12-1/4
D41 - 20 Blade	16-3/4
D41 - 22 Blade	21-1/2
D41 - 24 Blade	26

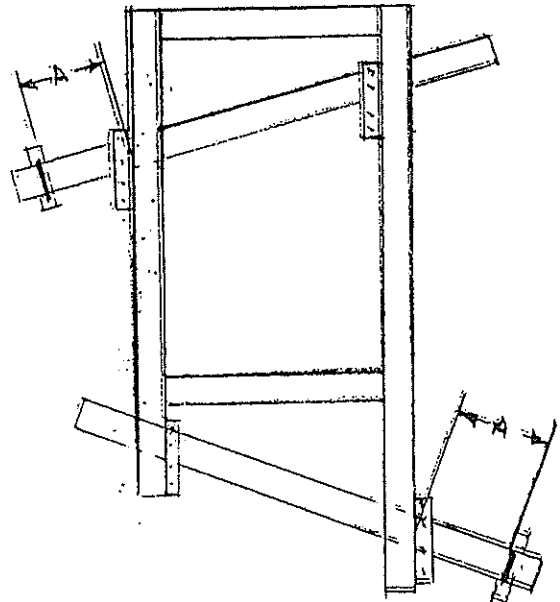

lubrication

Careful and regular attention to lubrication will greatly increase the life of the harrow. For economical and efficient operation, the proper lubrication of frame fittings, gang bearings, and wheel bearings is essential.

Be sure fittings are free of dirt before greasing. If a fitting is lost or damaged, replace it immediately. Lubricate all parts thoroughly with a good grade No. 2 gun grease (Lithium Base).

Miscellaneous working parts not provided with lubrication fittings should be oiled occasionally with a good grade of lubrication oil.

ROCKSHAFT RETAINER PINS: Grease every week or 50 hours of operation.

GANG BEARINGS: The AMCO wheel type offset disk harrow is equipped with triple sealed re-greasable ball bearings. The bearings are packed and greased at the factory. Grease these bearings every week or 50 hours of operation. **IMPORTANT** — apply grease with a low pressure, low volume hand grease gun. Use care to prevent damage to bearing seals. At the end of the season, all bearings should be greased, then raise the harrow on its wheels and spin the gangs slowly so that grease wraps around the bearing seals. This will help protect the seals from the elements during periods of storage.

HITCH STABILIZER: The hitch stabilizer should be greased every week or 50 hours of operation. The stabilizer should also be greased at the start of each season and at the end of each season. The threads on the stabilizer rod should be cleaned out and oiled occasionally for smooth operation.

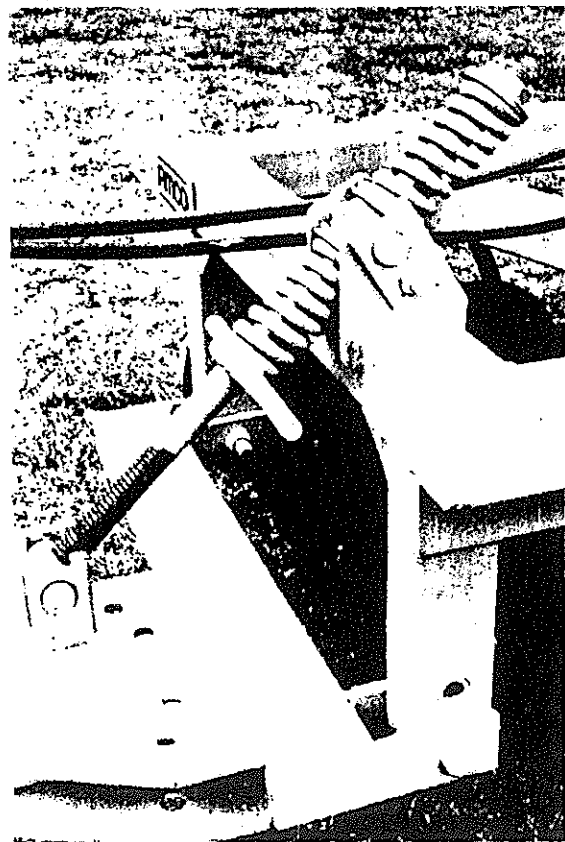

WHEEL BEARINGS: The wheel hubs are equipped with tapered roller bearings. These hubs are packed with grease and adjusted at the factory. They should be repacked and the spindle nut properly adjusted each season or every 300 hours of operation. Use a good grade No. 2 gun grease (Lithium Base).

Wheel bearings should be repacked with grease and adjusted annually. Under extreme conditions, they should be serviced more frequently. Check occasionally for excessive end play. Adjust as required to eliminate excessive end play.

To disassemble the hub, remove the wheel, then remove the dust cap by prying around it. Remove the cotter pin, slotted nut and flat washer. Carefully remove the hub and bearings from the spindle. Thoroughly clean and carefully inspect all parts for wear. All parts that appear to be worn or damaged must be replaced.

Use the following procedure when repairing or servicing wheel hubs:

1. Clean all parts that are to be re-used.
2. Carefully inspect the metal case on the grease seal. Discard the seal if the case is bent or damaged. Check seal lips for cuts, tears or excessive wear. Seal must fit snugly on extended inner race of bearing.
3. Carefully inspect both sets of bearing cones. Bearing bore and rollers must be smooth and free of nicks and scratches. Replace cones if damaged.
4. Inspect hub to make sure that the hub holes have a full thread. Bearing cones must be smooth and free of surface blemishes. Cups must be removed from the hub and replaced if damaged. Cups should be fully pressed into the hub and rest squarely against the shoulder inside the hub. Hub cap and grease seal should fit snugly inside the hub. Severely damaged hubs should be replaced.
5. Threads on spindle must be in good condition. Bearing cone seats must be smooth and free of blemishes. Bearing cones must fit squarely on the spindle.
6. Flat washer, slotted nut, cotter pin and hub cap must be in good condition. Replace if worn or damaged.

To reassemble the hub, repack each bearing cone with grease and fill the hub cavity 1/3 full of grease. Place inner bearing assembly in hub, press grease seal into hub and carefully re-install the hub on the spindle. Install the outer bearing assembly into the hub and replace the flat washer and slotted nut. Tighten the slotted nut to seat the bearings, until the hub binds when rotated.

Back the slotted nut to the nearest slot. Rotate the hub five or six revolutions in each direction to seat all parts. Re-tighten the slotted nut while rotating the hub. When the hub binds, back the nut off to the nearest slot, and install the cotter pin. Install the hub cap, and re-mount the wheel on the hub.

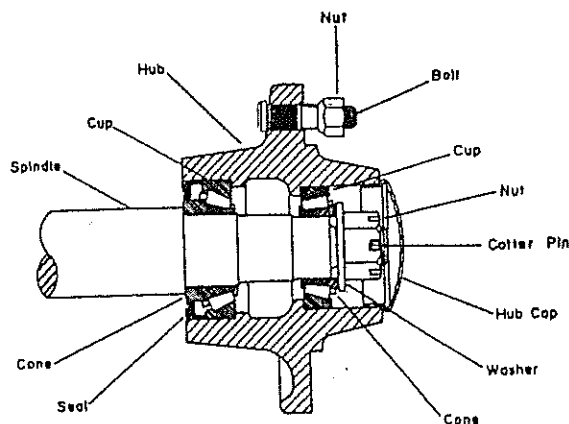

operating instructions

Your new AMCO offset disk harrow has been set-up, inspected, and adjusted by your dealer before delivery. However, before using your new harrow, or one that has been stored, check to make certain that all nuts and bolts are tight, all cotter pins spread and that the harrow has been lubricated.

This instruction manual should be carefully and thoroughly read to enable the operator to care for and operate the harrow.

The right and left hand sides of the harrow are determined by standing at the rear of the harrow and facing the direction of travel.

Refer to your tractor operator's manual for complete tractor operating instructions.

ADJUSTMENT FOR LEVEL DISKING: It is recommended that the tractor be operated at a speed best suited for soil conditions. High-speed disking will sometimes result in excessive lateral movement of the soil. This may leave an uneven surface behind the disk harrow known as "Ridging" or "Furrowing".

When disking in a cover crop or where the land is to be reworked, an uneven surface is not objectionable. If the land is to be bare through the winter, furrows and ridges will reduce soil washing, and will help catch and hold moisture, resulting in more water being absorbed by the soil.

FEATHERING BLADES: The use of feathering blades with smaller disks will move the excess soil back which is thrown out by the front gangs at high speeds. By using the feathering blades, the outside furrows are partially filled, giving a more uniform job of disking.

GROUND SPEED AND ADJUSTMENTS: Where it is necessary to have a level job of disking, the following factors must be taken into consideration: (1) Tractor Speed (2) Hitch Adjustment and (3) Disk Gang Angle Adjustment.

TRACTOR DRAWBAR: It is suggested that the tractor drawbar be set so it is free to swing when disking. This will prevent side draft, making operation of the harrow easier. The tractor drawbar will pull somewhat to the left side during operation. This is normal with an offset harrow.

HARROW HITCH: The harrow pull tongue can be offset to the right or left by using the set of holes in the cross tongue plates to obtain the desired offset.

SPRING LOADED STABILIZER: Penetration of front and rear gangs may vary. The spring loaded stabilizer may be adjusted to level the harrow front to rear. In extremely hard ground it may be necessary to shorten the stabilizer to force the front or penetrating gang into the ground. In normal conditions, the stabilizer should be adjusted so that the disk harrow is level front to rear while disking. The stabilizer may also be adjusted to level the unit for transport.

The type of work to be done by the harrow will determine the type of adjustment to be made.

Observe the harrow while it is working and check if the dead furrow is being filled and the ground left level. If not, an adjustment will have to be made.

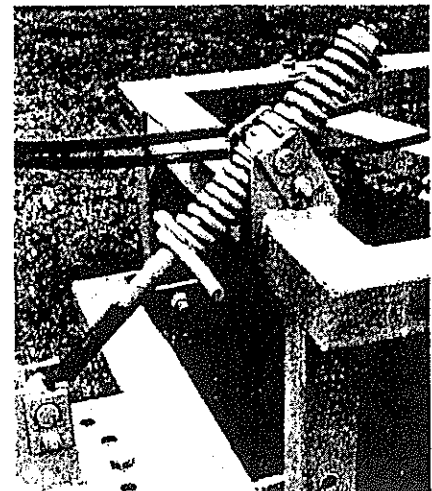

If the left blade of the rear gang is being "starved" for soil, move the rear gang slightly to the right or increase the rear gang cutting angle.

If the left blade of the rear gang is throwing too much soil, move the gang slightly to the left or decrease the rear gang cutting angle.

Changing the angle between the gangs will affect the penetration of the harrow. The wider the angle, the deeper the harrow will cut.

There are many factors which affect the way in which the soil will flow. Some factors are: moisture content of the soil, type of soil, speed of the tractor, depth of penetration, and working angle between the gangs. If any one of the conditions change, there will be a change in the resulting disking job.

Move the rear gang laterally one or two inches, or change the angle one hole at a time when making an adjustment.

To check the quality of disking being done, make one complete round and pass the points where the observation was made.

DISK GANG ANGLE: The gangs may be set at cutting angles 17, 20 and 23 degrees depending on soil conditions and job to be done. When conditions are near normal a setting between the two extremes is advisable for best operation. Use the set of holes in the main frame rails to select desired angles. The front gang angle can be increased by moving the gang forward. Moving the gang rearward will decrease the gang angle. Moving the rear gang forward will decrease the rear gang angle. Moving the rear gang to the rear will increase the rear gang cutting angle.

Increasing the cutting angle will increase penetration, soil pulverizing action and power requirements. Decreasing the cutting angle will have the opposite effect. Remember, always retorque gang frame mount bolts after making adjustments.

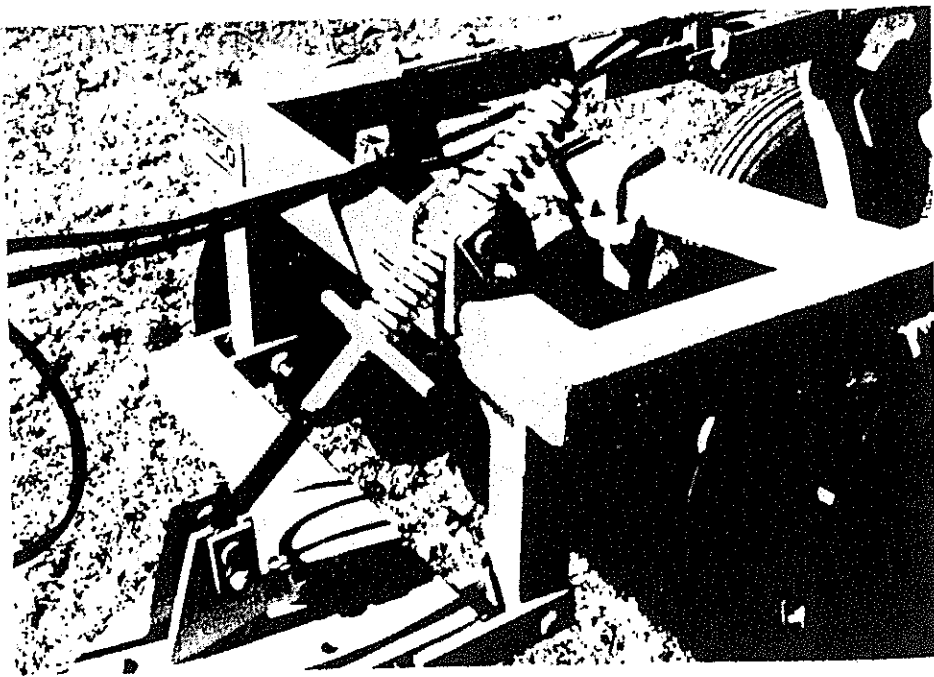

Disk as deep as necessary to do a thorough job but do not try to disk to an excessive depth. In most conditions, your AMCO harrow has ample weight for penetration. In other conditions, you may have a little more weight than you really need. Your harrow should be equipped with flotation tires for these conditions. 6.70 x 14 tires will be adequate for most conditions. You also need a good heavy duty, 4 x 8 or 3 x 8 hydraulic cylinder with stroke control. This will allow you to control your harrow cutting depth to meet all conditions. You should never allow soil to "bulldoze" ahead of or flow over the axle and spacer spools. Cutting depth should be controlled to avoid this situation. Maintaining proper cutting depth will have the following advantages:

1. Increased life of gang bearings.
2. Less strain on disk harrow frame. Therefore, the harrow will last longer.
3. Less load on your tractor engine and drive train.
4. Lower fuel consumption due to less load on tractor engine.
5. Less wheel slippage and less rear tractor tire wear due to lower load.
6. Higher tractor travel speeds due to less rear wheel slippage.

Therefore, by properly controlling the cutting depth, you can increase gang bearing life and cover more acres per day at a lower cost. In most cases it will not be necessary to reduce cutting depth by more than 1/2".

GANG LATERAL ADJUSTMENT: Front and rear gangs may be moved laterally for adjustments in extreme conditions. To make lateral gang adjustments, loosen the bolts that secure the gang frames to the main frame. Be sure to re-tighten the clamp bolts after making the adjustments.

SCRAPER ADJUSTMENT: Your Harrow is equipped with heavy duty scrapers. The scrapers should be adjusted so that the blade of the scraper slightly touches the disk blade yet allows the gang to turn freely. Each scraper can be adjusted individually by loosening the carriage bolt and sliding the scraper to the desired position. Always retighten the carriage bolt.

OFFSETTING THE HARROW: The harrow drawbar may be adjusted so the left tractor wheel can be run in the furrow if that is desirable. Or the left hand tractor wheel may be operated to the right of this furrow, or uncut ground, by making the compensating adjustment on the harrow drawbar. The fields may be laid out so right turns are made by lifting the harrow out of the ground before making the turn.

When the harrow is adjusted so it disks in an extreme left offset position, the front gang will assume a much greater angle (with respect to forward travel) than the rear gang. The rear gang will have a relatively small angle with respect to forward travel.

The small angle of the rear gang makes it more difficult to fill the dead furrow, but the condition can be corrected by using a rear gang adjustment. Usually, the rear gang will have to be shifted to the left.

In general when making a left offset, attempt to keep the amount of offset as small as possible.

The following points are important to remember when offsetting the harrow:

- Offsetting to the left increases the angle of the front gang and decreases the angle of the rear gang.
- Offsetting to the right decreases the angle of the front gang and increases the angle of the rear gang.

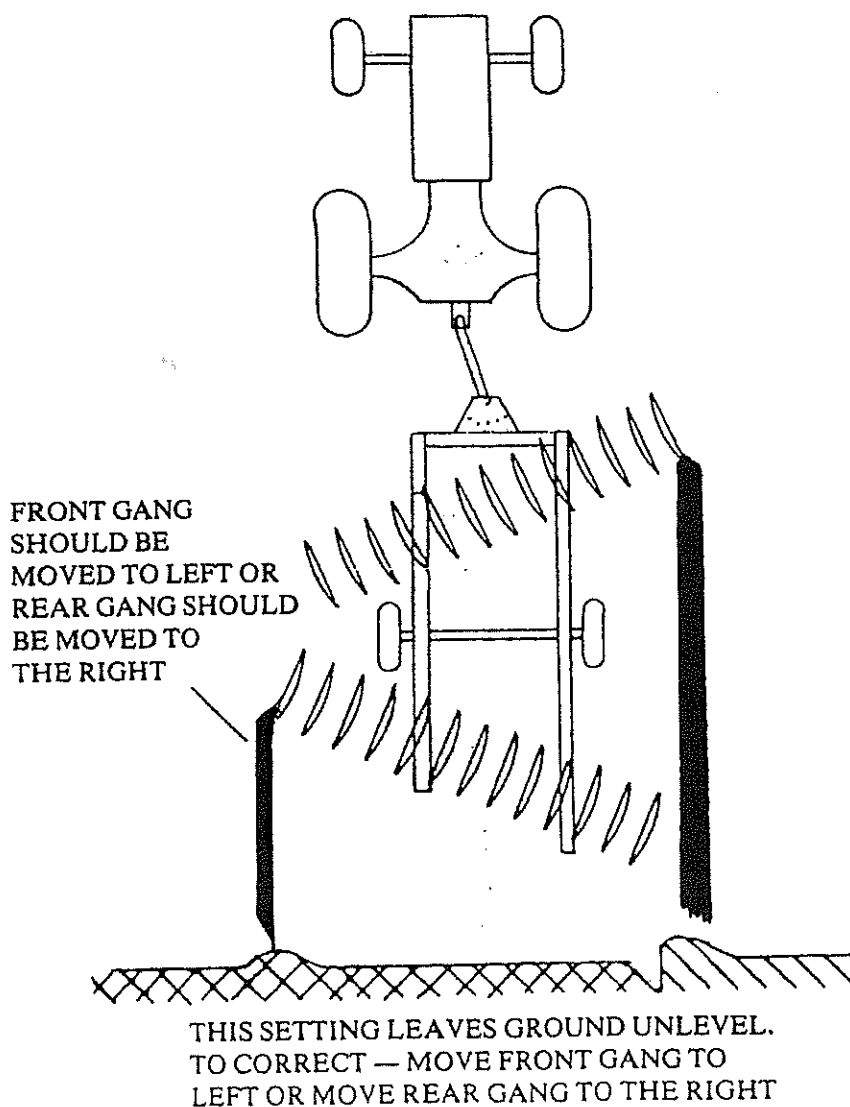

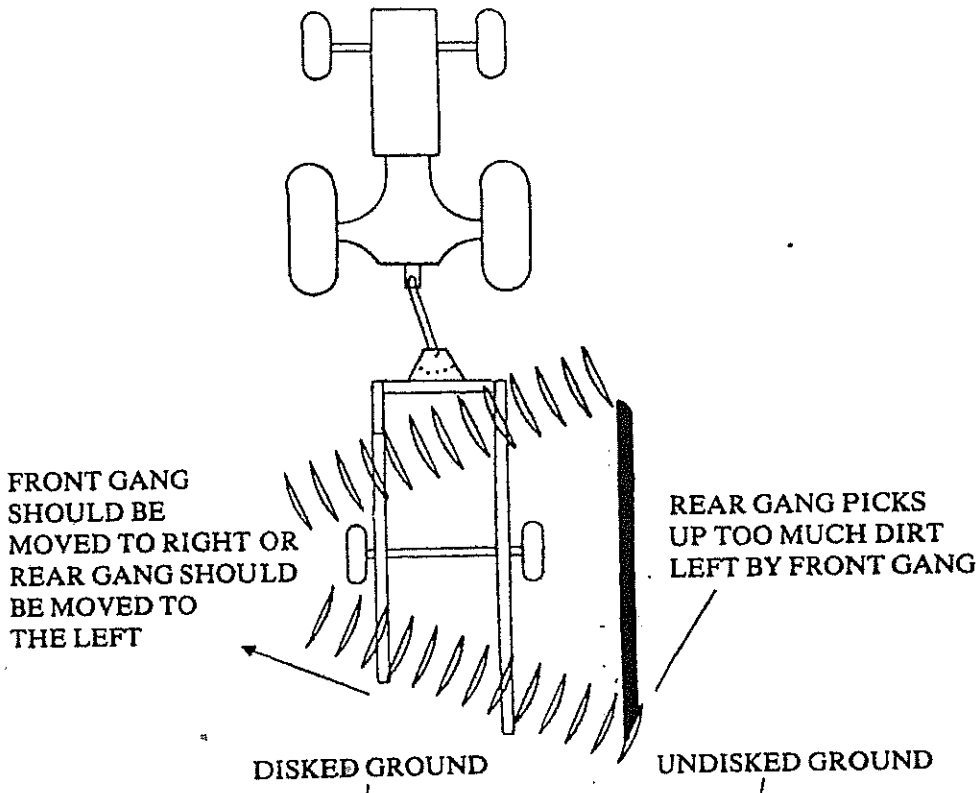

THIS SETTING LEAVES GROUND UNLEVEL.
 TO CORRECT — MOVE FRONT GANG TO RIGHT OR
 MOVE REAR GANG TO THE LEFT
 INCREASE THE ANGLE BETWEEN THE GANGS

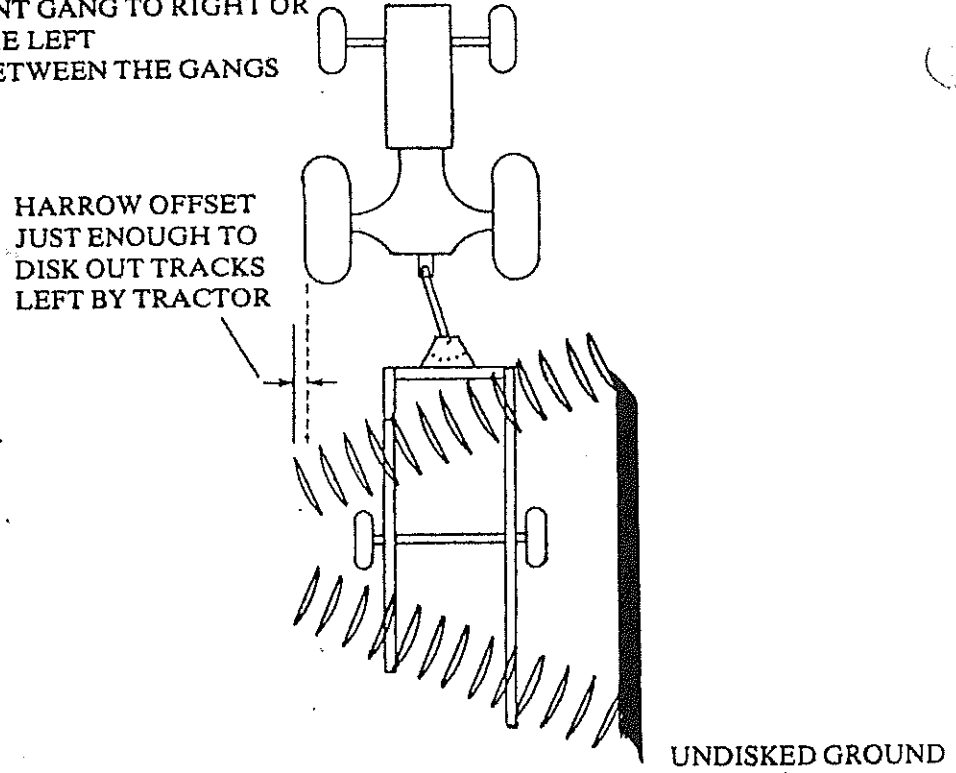

THIS IS CORRECT SETTING FOR LEVEL DISKING

TRANSPORT PIN: When transporting the disk harrow, always lock it in transport position with the transport pin. If the hydraulic cylinder is to be removed from the disk harrow, the transport pin should be installed before attempting to remove the cylinder.

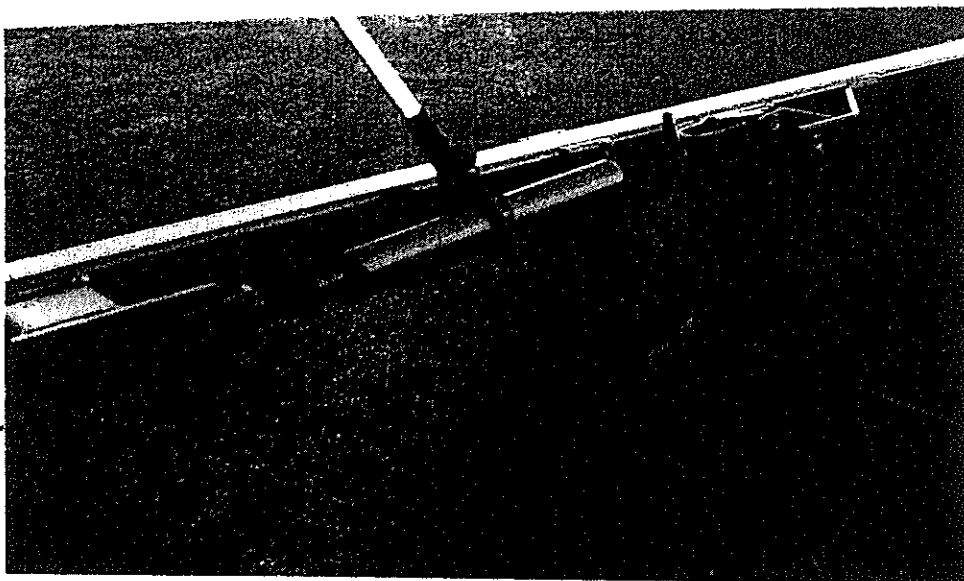

HYDRAULIC CYLINDER: Attach the rod end of the cylinder to the rockshaft lift arm and the butt end of the cylinder to the main frame as shown above. A heavy duty ASAE 3 x 8 hydraulic cylinder with stroke control is recommended for raising and lowering the disk harrow. Attach ratchett jack in place of hydraulic cylinder.

STORAGE: Proper storage will add to the life of your disk harrow, and assure its being in good condition for the next season. The following procedure is recommended:

Clean off all foreign matter, and lubricate the harrow.

Repaint the harrow where the original paint has worn off.

Coat the disk blades with a rust preventative.

Tighten all loose bolts and replace any damaged or missing parts.

All hydraulic cylinder rods should be fully retracted or coated with a rust preventative to prevent rusting in storage.

WARNING REFLECTORS: Attach a reflector with both red and amber reflective surfaces as near as possible to the extreme left rear part of the harrow. Mount the reflector so that the red surface is visible from the rear and the amber surface is visible from the front. Attach a red reflector as near as possible to the extreme right rear part of the harrow with the reflective surface visible from the rear.

SMV EMBLEM: The SMV (Slow Moving Vehicle) Emblem is a recommended attachment that should be added to your harrow. The SMV Emblem and warning reflectors can be purchased from your authorized AMCO dealer. A mounting bracket is located on the rear of the main frame for mounting a SMV Emblem.

WARNING LAMP: A warning lamp to be mounted on the extreme left hand rear of the harrow is available at your local AMCO dealer.



CAUTION When transporting farm implements on public roads after dusk, it is the responsibility of the operator to provide lighting and reflectors on the rear of the implement in accordance with your state law.



CAUTION When trailing the harrow over public roads, the SMV Emblem must be used, for protection of tractor and motor vehicle operators.

maintenance

1. Keep all bolts tight.
 - A. Check before placing in service.
 - B. Visually inspect all bolts daily.
 - C. Check after first 50 hours or one week's operation.
 - D. Check each season.
2. Keep wheel bearings properly adjusted.
 - A. Check often.
 - B. Clean and repack each season or every 300 hours.
 - C. Replace worn or damaged parts.
 - D. In dis-assembling and re-assembling the wheel hub assemblies, care must be taken to not damage the grease seal lips. In re-assembly, to seat the bearings, carefully tighten the hex nut until the hub drags. Rotate hub to help seat the bearing cups and cones. Re-tighten the hex nut until the hub drags, then back off the hex nut to the nearest slot and secure with cotter pin.
3. Do not run with loose disk blades. Keep gang bolts tight! Tighten gang bolts to 900-1000 ft-lbs of torque.
4. Keep scrapers properly adjusted.
5. Grease gang bearings and rockshaft retainer pins every week or 50 hours, at the start of each season, and at the end of each season. Apply with low pressure, low volume hand grease gun. Use a good No. 2 gun grease (Lithium Base). Rotate gangs while greasing for best results.
CAUTION. Use care to prevent damage to seals.
6. Disk Blade, Bearing, and Spool Replacement.
 - A. Remove the nuts that hold the gang bearing housing trunnion clamps.
 - B. Remove clamps.
 - C. Raise the harrow and roll the gang away from the frame.
 - D. Remove the gang nut lock plate.
 - E. Remove the gang hex nut from the end of the shaft.
 - F. Slide off the bearings, spools, spacers, and blades.
 - G. Avoid thread damage.
 - H. Tear the entire gang down and clean all parts. Check disk axle for straightness. Bowed, bent, or worn axles must be replaced.
 - I. Check spacer spools for damage caused by running disk with loose gangs or hitting underground obstructions. Replace spool if it is damaged.
 - J. Carefully check all end bells. The large end must contact the disk blade around the entire circumference of the end bell. The small end must be smooth and perpendicular to the axle. The end bells must be replaced if they are cracked or worn on the surface adjacent to the bearing.
 - K. Check all the bearings on the gang. Running a harrow for one hour or more after a bearing failure will seriously damage other bearings on the gang. This damaged bearing will then fail within a few hours after the failed bearing has been replaced. Continued operation with this failed bearing will damage the new bearing thus it will fail after a few hours use. In most cases it will be best to replace all bearings on a gang when it is torn down for repairs. A triple lip sealed bearing should always be used for bearing replacement. Also, a regreasable type bearing should always be used.

MOST OFTEN ENCOUNTERED DISK BLADE FAILURES

Most disk blade failures can be prevented by selecting the correct blade size for individual conditions when buying a disk. Reduction of speed in areas containing rocks and stumps will greatly lengthen the blade life. Keeping gang bolts properly torqued and raising the harrow while turning will also reduce disk blade breakage.

FIGURE 1 — Laminated Disc—defective steel. Eligible for warranty consideration.

SURFACE VIEW

EDGE VIEW

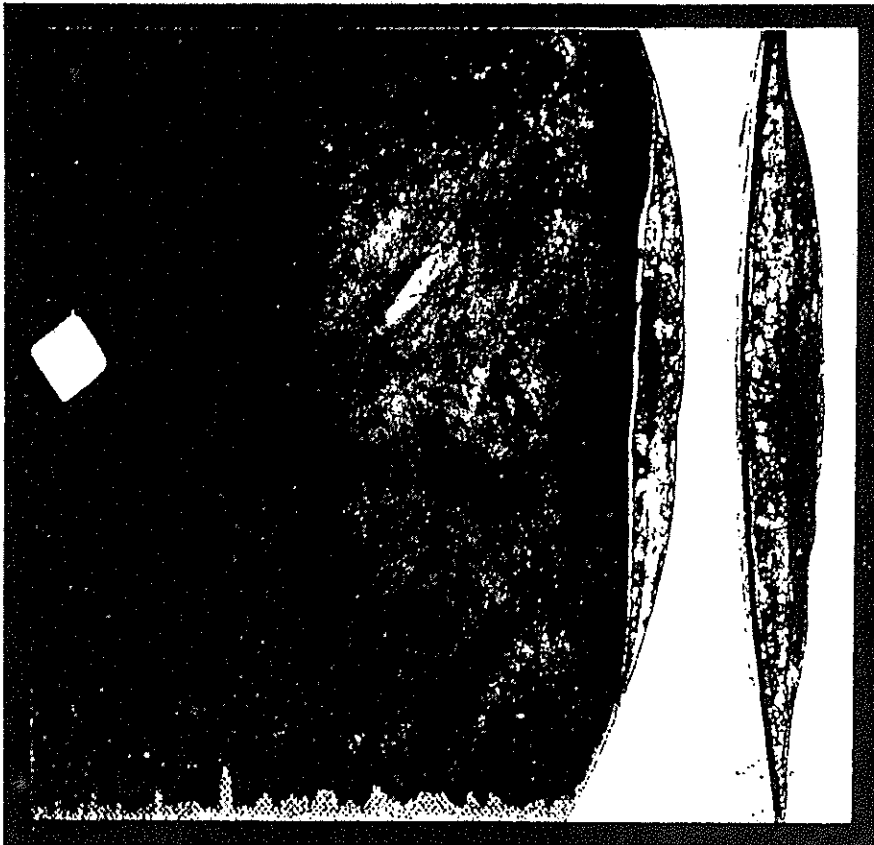
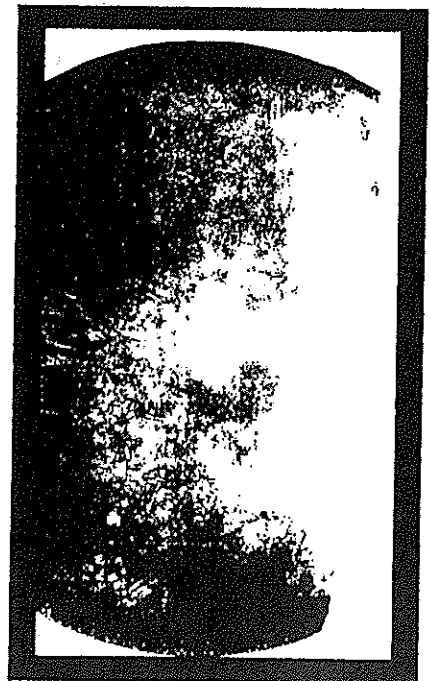

FIGURE 2 — Straight, directional break caused by defective steel. Eligible for warranty consideration.



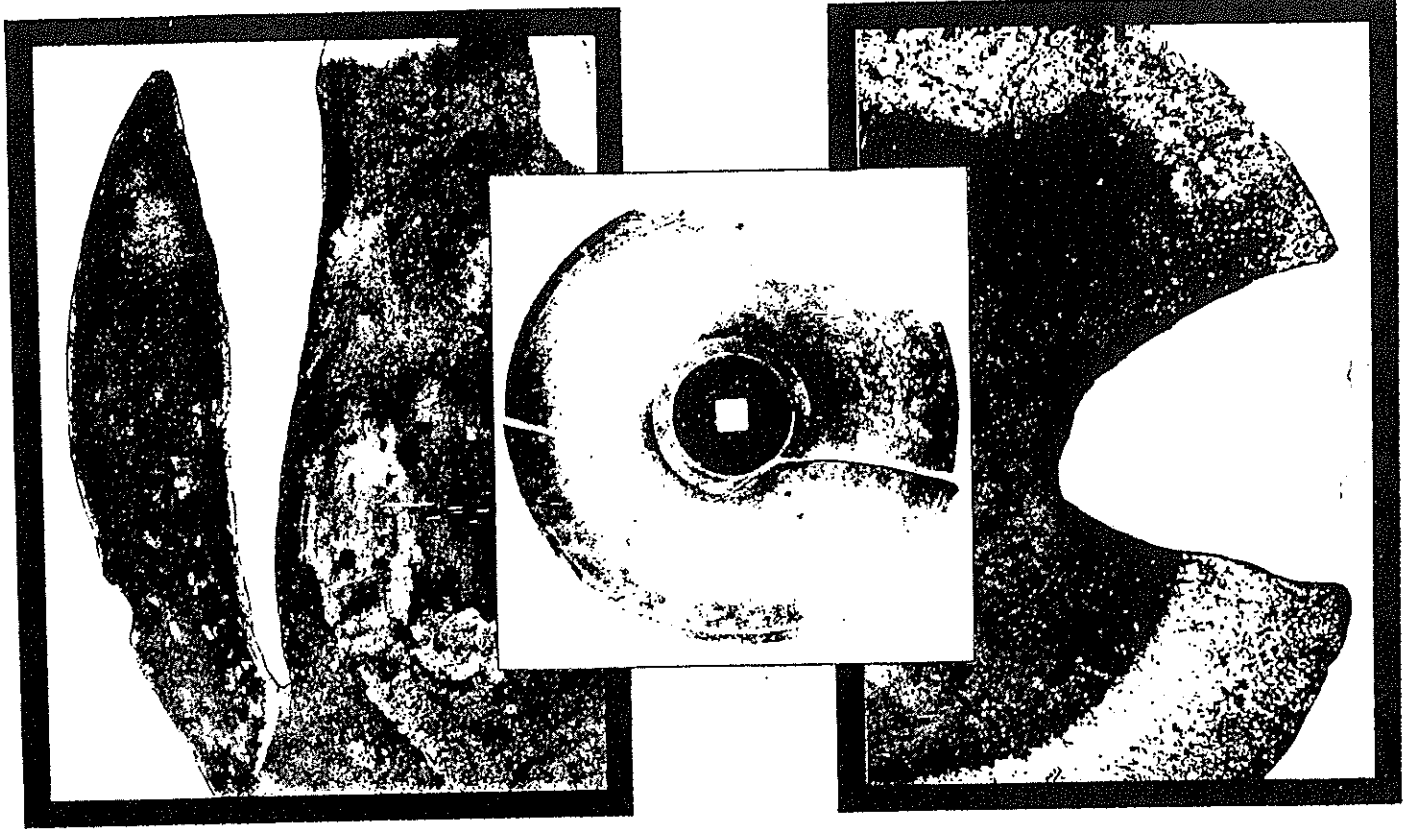

FIGURE 3, 4, 5 — Irregular breaks caused by contact against rocks or stumps. Not covered by warranty.



FIGURE 6 — Chipped or dented edges resulting from use in areas containing rocks or stumps. Not covered by warranty.



FIGURE 7 — Center broken out—Experience has shown that this is usually caused by loose bolts, excessive flexing, or by contact with rocks and stumps. Not covered by warranty.

Model

- D41 - 16 Blade
- D41 - 18 Blade
- D41 - 20 Blade
- D41 - 22 Blade
- D41 - 24 Blade

Measurement "A"

- 7-3/4
- 12-1/4
- 16-3/4
- 21-1/2
- 26

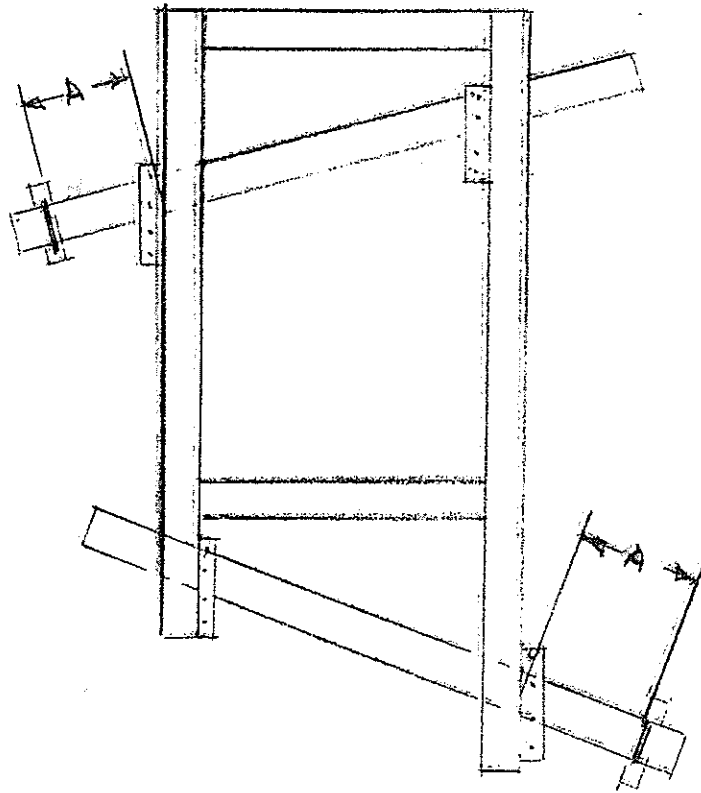

(

1
2
3

4
5
6

(

7
8
9

(