

Ref. No.	Part No.	Description	No. Req'd
16	10770	Carriage Bolt 1 x 7 NC	1
17	11027	Lock Washer 1"	1
18	11026	Hex Nut 1" NC	1
19	10068	Carriage Bolt 7/16 x 1-1/2 NC, PL	4
20	10619	Lock Washer 7/16 PL	4
21	10618	Hex Nut 7/16 NC, PL	4
	10551	Hydraulic Cylinder (Complete)	1
	10763	Seal Repair Kit	1
22	11095	Clevis Pins	2
23	11089	Cotter Pin	4
24	10919	Close Nipple	1
25	11088	Restrictor Assy	1
26	11083	Butt and Tube Assy	1
27	11086	Lock Nut	1
28	11085	Piston	1
29	11087	Snap Ring	1
30	11084	Gland	1
31	11082	Piston Rod Assy	1
	DD-01-0003	M-25 Kit for 2-1/2" Bar	
32	3427	Clamp Cap	2
33	10370	Carriage Bolt 7/8 x 5-1/2 NC	4
35	10396	Lock Nut NC PL	4
	DD-01-0007	M-35 Kit for 3-1/2" or 4" Bar	
36	0617	Assy Clamp Cap	2
37	9808	Thrust Bar	2
38	10945	Machine Bolt 7/8 Dia. x 9 Long NC, PL	4
40	10396	Lock Nut 7/8 NC PL	4
	DD-01-0002	M-47 Kit for 4" x 7" or 5" x 7" Bar	
41	9007	Lower Strap 10-1/2 Long	2
42	10945	Machine Bolt 7/8 x 9 NC, PL	4
43	10063	Cut Washer 7/8	4
45	10396	Lock Nut 7/8 NC, PL	4
	DD-01-0004	M-50 Kit for Pittsburg Planter	
46	9564	Clamp Plate 1/2 x 5 - 18" Long	2
47	10280	Hex Bolt 7/8 x 4 NC	4
49	10396	Lock Nut 7/8 NC, PL	4
50	11022	Hex Bolt 7/16 x 2 NC, PL	8
51	10619	Lock Washer 7/16 NC	8
52	10618	Hex Nut 7/16 NC, PL	8

## ASSEMBLY INSTRUCTIONS

### ASSEMBLY:

Your AMCO Row Marker is shipped in one sturdy, compact bundle. The row marker should be left in the bundle until you are ready to mount the row marker on a tool bar. The nut should be removed from the 5/8 Dia. rod. The two #1803 uprights should be clamped to the tool bar with two 7/8" Dia. bolts. The uprights should be attached at equal distances from the center of the tool bar. For four row applications the marker should be attached 72" to 85" from the tool bar center. On six row applications this distance should be 110" to 125". In most applications the upright should be 4" to 12" from the end of the tool bar.

The #0350 marker should then be attached to the marker uprights with the 1" Dia. pivot pins and 5/16 x 2-1/4 roll pins. The 2 x 8 hydraulic cylinder should then be attached to the upright and marker. The barrel should be attached to the upright and the rod to the #0350 marker. The restrictor on the cylinder is designed to restrict fluid flow into the cylinder for a smooth raising action. The restrictor should not restrict flow from the cylinder. This allows the marker to "Drop" without hesitation. The arrow on the restrictor should point away from the cylinder.

The blade should then be attached to the marker extension with the 1" Dia. carriage bolt.

### ADJUSTMENTS:

The marker extension should be set at the desired location for 4 or 6 row application. The blade should be set four row spacings from the tool bar center line for four row applications. The marker blade should be set six row spacings from the tool bar center line for six row applications. This distance can be adjusted by loosening the "U" bolt on the marker arm and sliding the extension to the desired location. The extension can be rotated to change the marker blade angle. A fairly large blade angle will work best in soils that are difficult to penetrate. The blade angle should be reduced to decrease penetration in light or sandy soils. The blade can be removed from the extension and reversed to run on the back side in extremely light soils. In general, the blade penetration should be deep enough to leave an adequate mark but shallow enough to prevent unnecessary strain on the row marker. Tighten the 1/2 Dia. "U" bolt when adjustments have been completed.

## Model 4-6H3 HYDRAULIC ROW MARKER

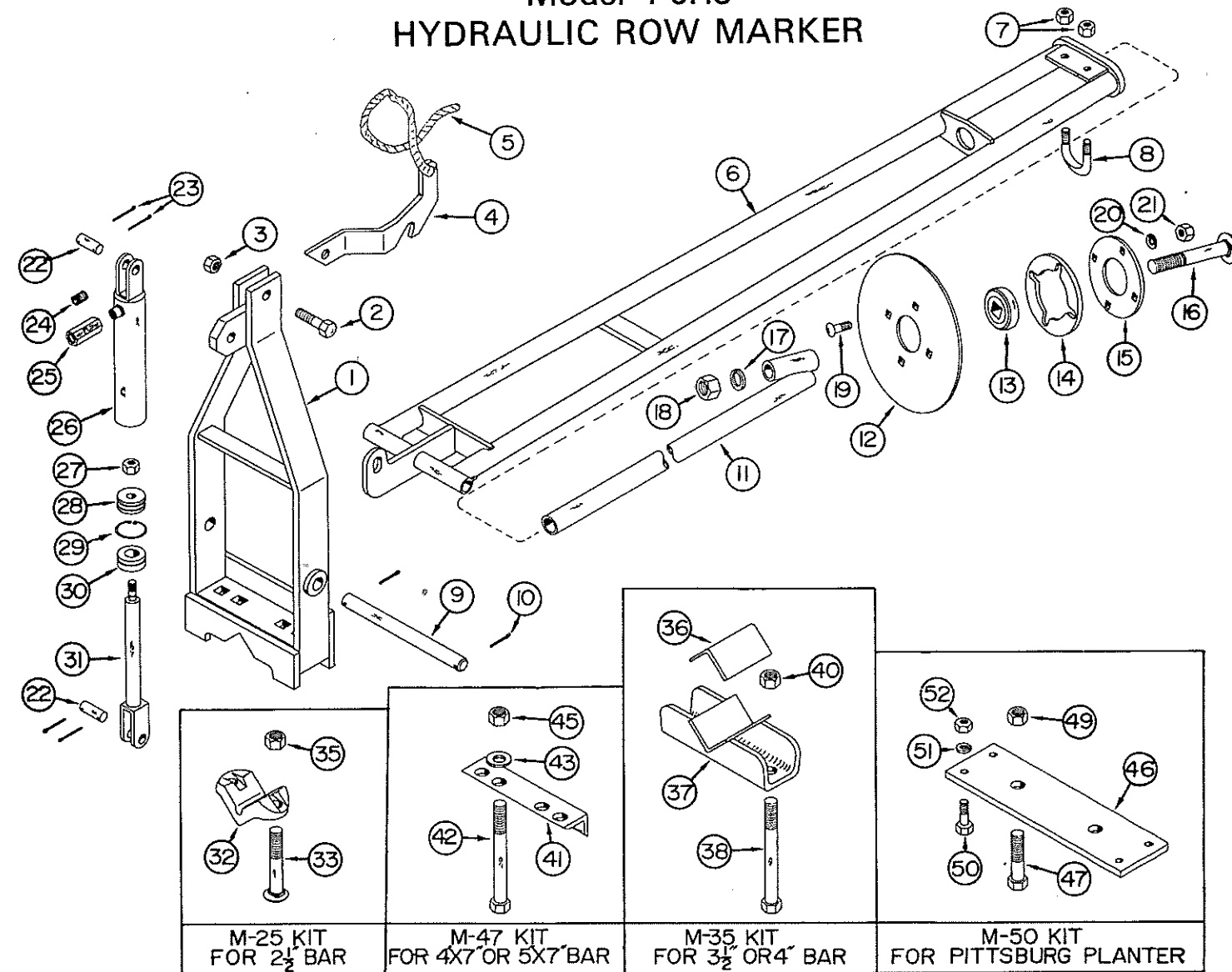

## PARTS LIST

Ref. No.	Part No.	Description	No. Req'd
	DD-01-0001	4-6H3 Row Marker	1
1	1803	Assy. Upright	1
2	10038	Hex Bolt 5/8 x 2-1/2 NC	1
3	10299	Lock Nut 5/8 NC	1
4	9545	Latch	1
5	10914	Rope 5/16" Dia. 165" Long	2
6	0350	Assy. Marker	1
7	10395	Lock Nut 1/2 NC PL	2
8	9759	"U" Bolt 1/2" Dia.	1
9	7188	Pivot Pin 1" Dia. 13" Long	1
10	10910	Roll Pin 5/16 x 2-1/4	2
11	0351	Assy. Extension	1
12	3270	Blade 16" Plain 10 GA.	1
13	11079	Bearing W208PPB6	1
14	7585	Bearing Spacer 5/16" 5-3/4" Dia.	1
15	10445	Flangette 80MSB	1