

AMCO J16

Attn: Parts Dept

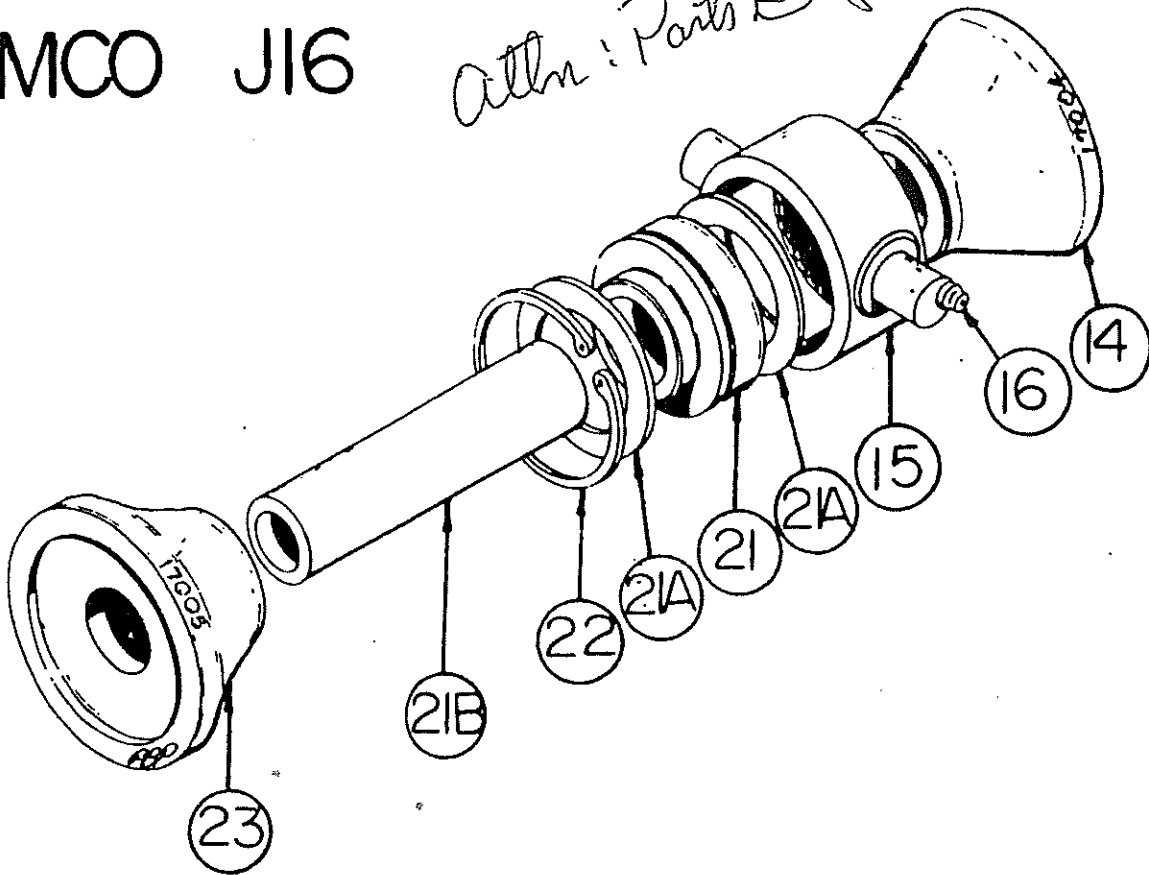

AMCO J16 Series
DISK HARROW

(Replacement Bearing and End Bells for all J16 Harrows with serial number 538 and up)

Ref. No.	Part No.	Description	No. Req'd.
14	17004	End Bell - Small	1 per bearing riser
	FB-09-0016	Sub. Assy. Bearing and Housing	
15	16014	Bearing Housing	1 per bearing riser
16	10606	Grease Fitting	1 per bearing housin
21	11504	Bearing 125mm DC214TTR3	1 per bearing housir
21A	100105	Washer 125mm	2 per bearing housir
22	11072	Retainer Ring	1 per bearing housi.
21B	100886	Sleeve	1 per bearing
23	17005	End Bell - Large	1 per bearing riser

use 0946 Spacer Spool 10-1/4" w/ Boob
w/ Blades - 6" Pipe -

0947 - 10-1/2" Spacer Spool Without Boob w/
Blades 6" Pipe -

WOF16 REAR GANG

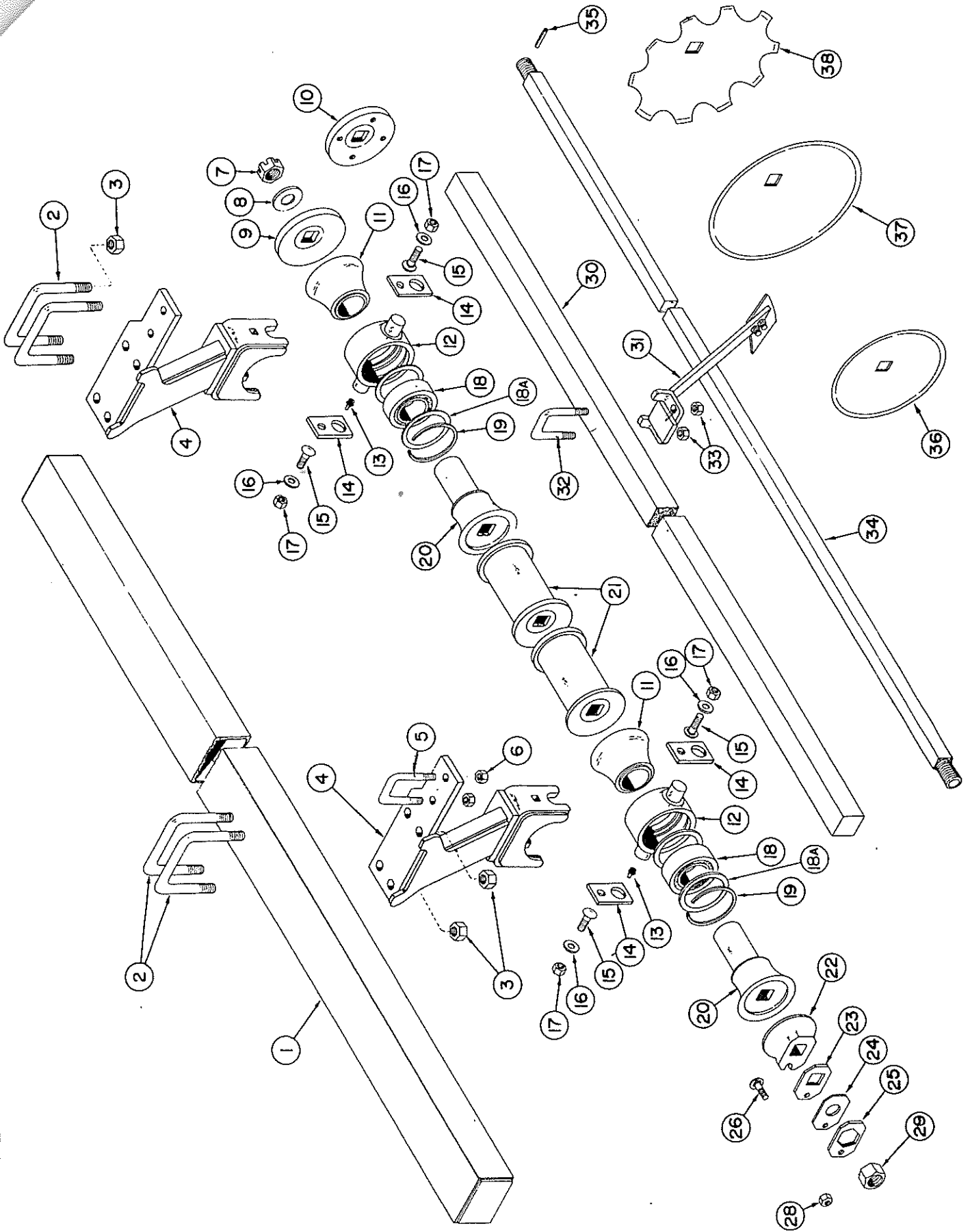

**AMCO WOF16
REAR GANG**

Ref. No.	Part No.	Description	No. Req'd
28	10395	Lock Nut 1/2-NC, PL, (1 per Gang Bolt)	A.R.
29	10489	Nut-Gang Bolt 1 1/2 - NF, CH (1 per Gang Bolt)	A.R.
30	100336	Scraper Bar 94" - 20 Blade.	1
30	100337	Scraper Bar 102" - 22 Blade.	1
30	100338	Scraper Bar 108" - 24 Blade.	1
30	100339	Scraper Bar 117" - 26 Blade.	1
30	100340	Scraper Bar 126" - 28 Blade.	1
30	100342	Scraper Bar 144" - 32 Blade.	1
30	100343	Scraper Bar 165" - 36 Blade.	1
30	100344	Scraper Bar 183" - 40 Blade.	1
30	100346	Scraper Bar 200" - 44 Blade.	1
31	0709A	Scraper (1 per Blade)	A.R.
32	100002	"U" Bolt 5/8 Dia. (1 per Scraper)	A.R.
33	10299	Lock Nut 5/8 - NC, PLT, (2 per Scraper).	A.R.
34	9441	Gang Bolt 42 7/8" - 5 Blade	A.R.
34	9442	Gang Bolt 52 1/8" - 6 Blade	A.R.
34	9443	Gang Bolt 61 3/8" - 7 Blade	A.R.
34	9444	Gang Bolt 70 5/8" - 8 Blade	A.R.
34	9446	Gang Bolt 89 1/8" - 10 Blade	A.R.
34	9447	Gang Bolt 98 3/8" - 11 Blade	A.R.
35	10910	Roll Pin 5/16 x 2 1/4 (1 per Gang Bolt).	A.R.
36	3278	Blade 10" x 11 Ga. Back-Up	A.R.
37	3276	Blade 22 x 1/4 Plain	A.R.
37	3255	Blade 24 x 1/4 Plain	A.R.
37	3263	Blade-26 x 1/4 Plain	A.R.
38	3275	Blade 22 x 1/4 C.O.	A.R.
38	3250	Blade-24 x 1/4 C.O.	A.R.
38	2456	Blade 26 x 1/4 C.O.	A.R.

**AMCO WOJ16
REAR GANG**

Ref. No.	Part No.	Description	No. Req'd
1	0700	Gang Frame 94" - 18 Blade	1
1	0503	Gang Frame 102" - 20 Blade	1
1	0505	Gang Frame 117" - 22 Blade	1
1	0506	Gang Frame 126" - 24 Blade	1
1	0507	Gang Frame 135" - 26 Blade	1
1	0508	Gang Frame 144" - 28 Blade	1
1	0487	Gang Frame 165" - 32 Blade	1
1	0519	Gang Frame 187" - 36 Blade	1
1	0493	Gang Frame 209" - 40 Blade	1
1	9752	"U" Bolt 7/8 Dia. (2 per Bearing Riser)	A.R.
3	10396	Lock Nut 7/8 - NC, PL (4 per Bearing Riser)	A.R.
4	0702	Bearing Riser - LH.	A.R.
5	100002	"U" Bolt 5/8 Dia. (1 per Bearing Riser)	A.R.
6	10299	Lock Nut 5/8 - NC PLT (2 per Bearing Riser)	A.R.
7	10226	Nut-Gang Bolt 1 1/2 - NC, Slotted (1 per Gang Bolt)	A.R.
8	10872	Cut Washer 1 3/8 - PLT (1 per Gang Bolt)	A.R.
9	2404	Bumper Washer (1 per Gang)	A.R.
10	2404-A	Bumper Washer (Use On R.H. Gang Only)	1
11	6402	End Bell-Small (1 per Bearing Riser)	A.R.
12	16014	Bearing Housing (1 per Bearing Riser)	A.R.
13	10606	Grease Fitting (1 per Bearing Housing)	A.R.
14	9981	Clamp-Trunion, (3/8 x 2 1/2 x 4) (2 per Bearing Riser)	A.R.
15	10665	Carriage Bolt 5/8 x 2 - NC, PLT, GR5 (2 per Bearing Riser)	A.R.
16	10059	Cut Washer 5/8 - PLT (2 per Bearing Riser)	A.R.
17	10299	Lock Nut 5/8 - NC, PLT (2 per Bearing Riser)	A.R.
18	G10218	Bearing GW214-PP2 (1 per Bearing Riser)	A.R.
18A	100105	Washer 125mm (2 per Bearing Housing)	A.R.
	FB-09-0014	Bearing & Housing - Complete	
19	11072	Retainer Ring (1 per Bearing)	A.R.
20	6403	End Bell-Large (1 per Bearing Riser)	A.R.
21	1296	Spacer Spools (Use 0523 For Harrows Less Back-Up Blades)	A.R.
22	1222-A	End Gang Washer (1 per Gang Bolt)	A.R.
23	100099	Spacer Plate	A.R.
24	100098	Bearing Plate (1 per Gang Bolt)	A.R.
25	5622-A	Lock Plate (1 per Gang Bolt)	A.R.
26	10870	Carriage Bolt 1/2 x 1 1/2 - NC, PL, GR5 (1 per Gang Bolt Without 100099 Spacer Plate)	A.R.
26	10710	Carriage Bolt 1/2 x 2 - NC, PL, GR5 (1 per Gang Bolt With 100099 Spacer Plate)	A.R.
28	10395	Lock Nut 1/2 - NC, PL (1 per Gang Bolt)	A.R.
29	10489	Nut-Gang Bolt 1 1/2 - NF, CH (1 per Gang Bolt)	A.R.
30	100336	Scraper Bar 94" - 18 Blade	1
30	100337	Scraper Bar 102" - 20 Blade	1
30	100339	Scraper Bar 117" - 22 Blade	1
30	100340	Scraper Bar 126" - 24 Blade	1

(Cont.'d next page)

WOJ 16 FRONT GANG

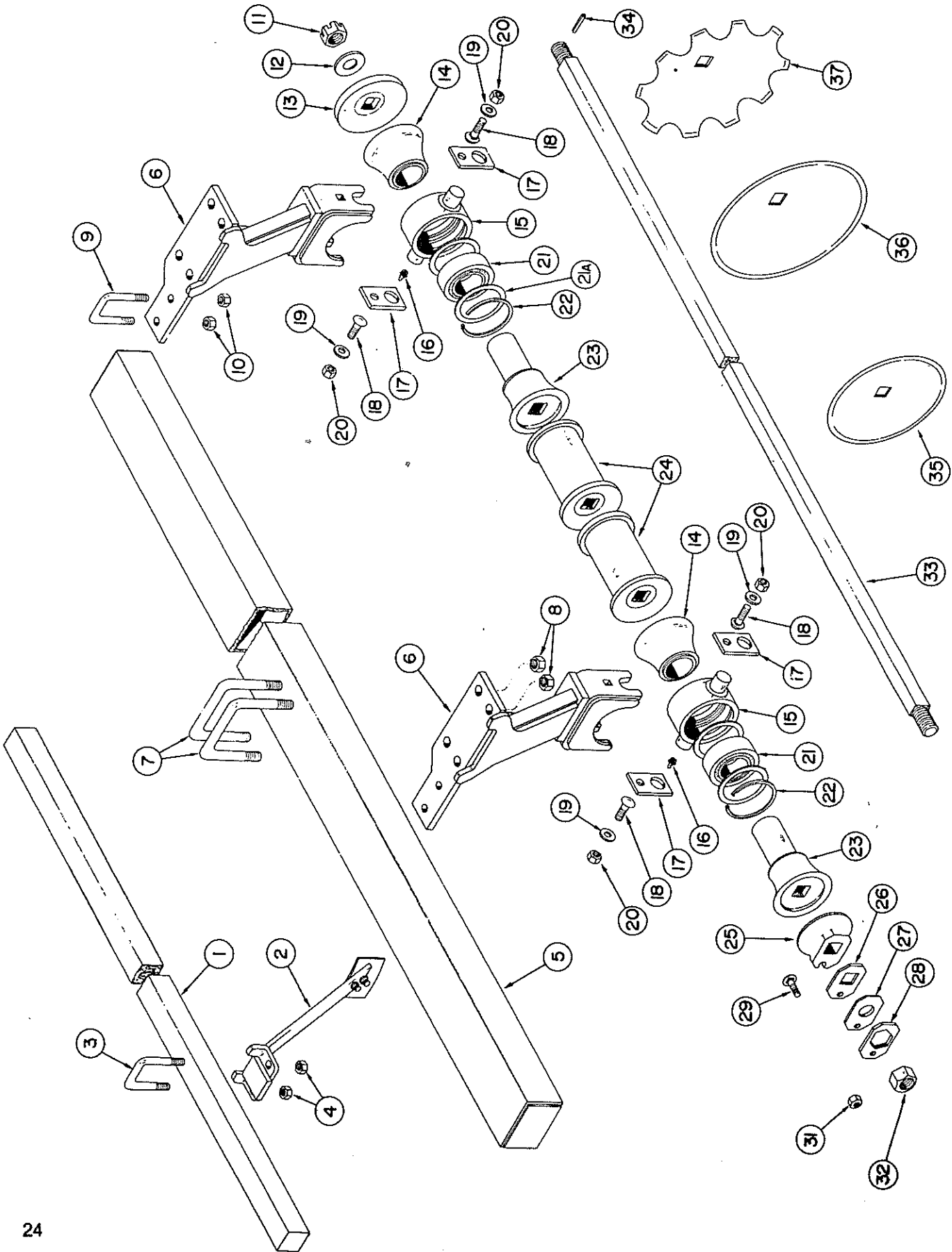

**AMCO WOJ16
FRONT GANG**

Ref. No.	Part No.	Description	No. Req'd
1	100336	Scraper Bar 94" - 18 Blade.	1
1	100337	Scraper Bar 102" - 20 Blade.	1
1	100339	Scraper Bar 117" - 22 Blade.	1
1	100340	Scraper Bar 126" - 24 Blade.	1
1	100341	Scraper Bar 135" - 26 Blade.	1
1	100342	Scraper Bar 144" - 28 Blade.	1
1	100343	Scraper Bar 165" - 32 Blade.	1
1	100345	Scraper Bar 187" - 36 Blade.	1
1	100347	Scraper Bar 209" - 40 Blade.	1
2	0708A	Scraper (1 per Blade)	A.R.
3	100002	"U" Bolt 5/8 - Dia. (1 per Scraper)	A.R.
4	10299	Lock Nut 5/8 - NC, PLT (2 per Scraper)	A.R.
5	0700	Gang Frame 94" - 18 Blade	1
5	0503	Gang Frame 102" - 20 Blade	1
5	0505	Gang Frame 117" - 22 Blade	1
5	0506	Gang Frame 126" - 24 Blade	1
5	0507	Gang Frame 135" - 26 Blade	1
5	0508	Gang Frame 144" - 28 Blade	1
5	0487	Gang Frame 165" - 32 Blade	1
5	0519	Gang Frame 187" - 36 Blade	1
5	0493	Gang Frame 209" - 40 Blade	1
6	0701	Bearing Riser - RH	A.R.
7	9752	"U" Bolt 7/8 Dia. (2 per Bearing Riser)	A.R.
8	10396	Lock Nut 7/8 - NC, PL (4 per Bearing Riser)	A.R.
9	100002	"U" Bolt 5/8 Dia. (1 per Bearing Riser)	A.R.
10	10299	Lock Nut 5/8 - NC, PLT (2 per Bearing Riser)	A.R.
11	10226	Nut Gang Bolt 1 1/2 - NF, Slotted (1 per Gang Bolt)	A.R.
12	10872	Cut Washer 1 3/8 - PLT (1 per Gang Bolt)	A.R.
13	2404	Bumper Washer (1 per Gang)	A.R.
14	6402	End Bell - Small (1 per Bearing Riser)	A.R.
15	16014	Bearing Housing (1 per Bearing Riser)	A.R.
16	10606	Grease Fitting (1 per Bearing Housing)	A.R.
17	9981	Clamp-Trunion 3/8 x 2 1/2 x 4 (2 per Bearing Riser)	A.R.
18	10665	Carriage Bolt 5/8 x 2 - NC, PLT, GR5 (2 per Bearing)	A.R.
19	10059	Cut Washer 5/8 - PLT (2 per Bearing Riser)	A.R.
20	10299	Lock Nut 5/8 - NC, PLT (2 per Bearing Riser)	A.R.
21	G10218	Bearing GW214-PP2 (1 per Bearing Riser)	A.R.
21A	100105	Washer 125mm (2 per Bearing Housing)	A.R.
	FB-09-0014	Bearing & Housing - Complete	
22	11072	Retainer Ring (1 per Bearing)	A.R.
23	6403	End Bell-Large (1 per Bearing Riser)	A.R.
24	1296	Spacer Spool (Use 0523 for harrows less back-up blades)	A.R.
25	1222-A	End Gang Washer (1 per Gang)	A.R.

(Cont.'d next page)

5

**AMCO WOJ16
FRONT GANG**

Ref. No.	Part No.	Description	No. Req'd
26	100099	Spacer Plate	A.R.
27	100098	Bearing Plate (1 per Gang Bolt)	A.R.
28	5622-A	Lock Plate (1 per Gang Bolt)	A.R.
29	10870	Carriage Bolt 1/2 x 1 1/2-NC, PLT, GR5 (1 per Gang Bolt Without 100099 Spacer Plate)	A.R.
29	10710	Carriage Bolt 1/2 x 2 - NC, PL, GR5 (1 per Gang Bolt Used With 100099 Spacer Plate)	A.R.
31	10395	Lock Nut 1/2 - NC, PL (1 per Gang Bolt)	A.R.
32	10489	Nut-Gang Bolt 1 1/2-NF, CH (1 per Gang Bolt)	A.R.
33	9444	Gang Bolt 70 5/8" - 7 Blade	A.R.
33	9450	Gang Bolt 49 1/2" - 5 Blade	A.R.
33	9451	Gang Bolt 60 1/4" - 6 Blade	A.R.
33	9454	Gang Bolt 92 1/2" - 9 Blade	A.R.
33	9455	Gang Bolt 103 1/4" - 10 Blade	A.R.
34	10910	Roll Pin 5/16 x 2 1/4 (1 per Gang Bolt)	A.R.
35	3278	Blade 10" x 11-Ga. Back-Up	A.R.
36	3276	Blade-22 x 1/4 Plain	A.R.
36	3255	Blade 24 x 1/4 Plain	A.R.
36	3263	Blade 26 x 1/4 Plain	A.R.
37	3275	Blade-22 x 1/4 C.O.	A.R.
37	3250	Blade 24 x 1/4 C.O.	A.R.
37	2456	Blade 26 x 1/4 C.O.	A.R.

9456 Gang bolt - 110" - 11 Blade
(For 40 Blade J.R. Gang Bolt)