

**** LF6 ** LJ6 ****
AMCO LEVEE PLOW

OPERATOR'S MANUAL
PART IDENTIFICATION



LEVEE PLOW

Revised 10/2017

AMCO MANUFACTURING COMPANY

800 South Industrial Parkway • P.O. Box 1107
Yazoo City, Mississippi (MS) 39194 USA
(662) 746-4464 • Toll Free: (800) 748-9022 • Fax: (662) 746-6825
www.amcomfg.com

TABLE OF CONTENTS

Foreword.....	3
Safety.....	4
Specifications & Tractor Horsepower Recommendations.....	5
Bolt Torque.....	7
Warning Decals.....	8
Levee Plow Components.....	10
Hitching the Levee Plow to the Tractor.....	11
Unhitching the Levee Plow from the Tractor.....	12
Checklist before Using the Levee Plow.....	12
Transportation.....	13
Maintenance & Lubrication.....	14
Levee Plow Extended Storage.....	15
Operating the Levee Plow.....	16
Levee Plow Adjustments.....	17
Levee Construction Instructions.....	18
Levee Tear down Setting Instructions.....	18
Hydraulic System Troubleshooting Guide.....	19
Tips for Satisfactory Operation.....	20
Parts List Section For all Models.....	25
Troubleshooting Guide.....	32

FOREWORD

You've just joined an exclusive but rapidly growing club.

For our part, we want to welcome you to the group and thank you for buying an AMCO product.

We hope your new AMCO implement will help you achieve both increased productivity and increased efficiency so that you may generate more profit.

This operator's manual has been designed into five major sections: Foreword, Safety Precautions, Operation, Troubleshooting and Parts Identification.

It is important the owner/operator knows the implement model number and serial number. Write the serial and model number in the space provided and use it in all correspondence when referring to the implement.

Throughout the manual, references may be made to left side and right side. These terms are used as viewed from the operator's seat facing the front of the tractor.



This **SAFETY ALERT SYMBOL** indicates important safety messages in the manual. When you see this symbol, be alert to the possibility of **PERSONAL INJURY** and carefully read the message that follows.

The word **NOTE** is used to convey information that is out of context with the manual text. It contains special information such as specifications, techniques, reference information and other information of a supplementary nature.

The word **IMPORTANT** is used in the text when immediate damage will occur to the machine due to improper technique or operation. Important will apply to the same information as specified by **NOTE** only of an immediate and urgent nature.

It is the responsibility of the user to read the operator's manual and comply with the safe and correct operating procedure and to lubricate and maintain the product according to the maintenance schedule in the operator's manual.

The user is responsible for inspecting his machine and for having parts repaired or replaced when continued use of the product would cause damage or excessive wear to the other parts.

It is the user's responsibility to deliver his machine to the AMCO dealer who sold him the product for service or replacement of defective parts that are covered by the warranty policy.

If you are unable to understand or follow the instructions provided in the publication, consult your local AMCO dealer or contact:

AMCO MANUFACTURING, INC.

662-746-4464

800-748-9022

662-746-6825 (FAX)

Website: www.amcomfg.com

E-mail: sales@amcomfg.com
parts@amcomfg.com

AMCO Manufacturing warrants all products manufactured and sold by it against defects in material. This warranty being expressly limited to replacement at the factory of such parts or products as will appear to be defective after inspection.

This warranty does not obligate the Company to bear cost of labor in replacement of parts. It is the policy of the company to make improvements without incurring obligations to add them to any unit already sold. No warranty is made or authorized to be made, other than herein set forth. This warranty is in effect for one year after purchase.

Model Number: _____

Serial Number: _____

Dealer: _____

AMCO Manufacturing warrants its own products only and cannot be responsible for damage to equipment on which mounted.

SAFETY

A brief description of signal words that may be used in this manual:

CAUTION: Used as a general reminder of good safety practices or to direct attention to unsafe practices.

WARNING: Denotes a specific potential hazard.

DANGER: Denotes the most serious specific potential hazard.

SAFETY PRECAUTIONS

You can make your farm a safer place to live and work if you observe the safety precautions given. Study these precautions carefully and insist that they be followed by those working with you and for you.



WARNING

Never clean, lubricate or adjust a machine that is in motion. Always lower or block the implement before performing service.

If machine must be serviced in the raised position, jack or block it up to prevent it from accidentally falling and injuring someone.

Do not allow riders on the tractor or implement.

Use speeds and caution dictated by the terrain being traversed. Do not operate on any slope steep enough to cause tipping or loss of control.

Be sure all personnel are clear of the immediate area before operating.

Read and understand the operator's manual and require all other persons who will operate the equipment to do the same.

Be familiar with all tractor and implement controls and be prepared to stop engine and implements quickly in an emergency.



Consult your implement and tractor operator's manual for correct and safe operating practices.

Beware of towed implement width and allow safe clearance.

FAILURE TO HEED MAY RESULT IN PERSONAL INJURY OR DEATH.

SPECIFICATIONS AND SUGGESTED HORSEPOWER REQUIREMENTS

Hydraulic

Model	Adjustable Cutting Width	No. of Disc Blades	Blade Spacing	Approx. Engine HP Required	Approx. Weight lbs
LF6-824	8'11" to 9'11"	8	9"	108-169	2,060
LF6-1024	10'5" to 11'5"	10	9"	122-203	2,260
LF6-1224	11'11" to 12'11"	12	9"	135-236	2,460
LJ6-824	9'5" to 10'5"	8	10½"	115-189	2,160
LJ6-1024	11'1" to 12'1"	10	10½"	135-216	2,360
LJ6-1224	12'9" to 13'9"	12	10½"	155-243	2,560

Manual

Model	Adjustable Cutting Width	No. of Disc Blades	Blade Spacing	Approx. Engine HP Required	Approx. Weight lbs
MLF6-824	8'11" to 9'11"	8	9"	108-169	2,060
MLF6-1024	10'5" to 11'5"	10	9"	122-203	2,260
MLF6-1224	11'11" to 12'11"	12	9"	137-238	2,460
MLJ6-824	9'5" to 10'5"	8	10½"	115-189	2,160
MLJ6-1024	11'1" to 12'1"	10	10½"	135-216	2,360
MLJ6-1224	12'9" to 13'9"	12	10½"	155-243	2,560

BOLT TORQUE





WARNING

Before making any adjustments, inspections, lubricating or repairing. Slowly lower the Levee Plow until it is firmly in contact with the ground. Before dismounting from the tractor shut off the engine set the parking brake and remove the key.

READ THESE INSTRUCTIONS FIRST:

1. Improperly tightened bolts will result in damage, breakage, expense, and down time.
2. Always replace bolts with the specified grade and type.
3. Torque bolts using a torque wrench properly before first use of the machine and every 2-4 hours of use until you are sure bolts are staying tight.
4. The chart below is a guide for proper torque. Use it unless a specified torque is called out elsewhere in the manual.

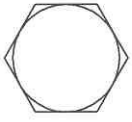
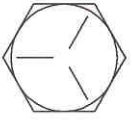
The following table shows torque in ft. lbs.

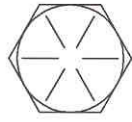
BOLT DIA. AND THREADS PER INCH	 GRADE 2	 OR  GRADE 5 A-325	 GRADE 8
3/8-16	25	35	50
7/16-14	35	55	80
1/2-13	55	85	125
9/16-12	75	125	175
5/8-11	105	170	235
3/4-10	185	305	425
7/8-9	170	445	690
1-8	260	670	1030
1 1/8-7	365	900	1460
1 1/4-7	515	1275	2060
1 3/8-6	675	1675	2700
1 1/2-6	900	2150	3500
1 3/4-5	1410	3500	5600

Shear Bolt Torque Rating

Metric bolt torque for M12 Class 8.8 zinc plated is 55.1 foot-pounds.

WARNING DECALS

Familiarize yourself with the warning decals affixed to the plow. It is important for you to operate the plow safely. Read and follow the safety directions on all warning decals.

1. For operator safety make sure all warning decals are clean and legible.
2. Immediately replace any damaged or missing warning decals.
3. Never cover or obscure a warning decal.
4. Refer to the Parts Identification Section of this manual for correct warning decal locations.
5. Replacement warning decals can be obtained from your AMCO Dealer or by contacting AMCO at amcomfg.com.

HYDRAULIC LEVEE PLOW

MODELS "LF6" and "LJ6"

9" or 10-1/2" Spacing

(F) & (J) series

STANDARD SPECIFICATIONS

(Metrics in Parentheses)

Axles	1-1/2" sq. high carbon cold rolled steel	Gang Angle:	18" to 28"
Blades	24" x 1/4" (6mm) Plain with 10" backup blade behind outside blades	Tilt Indicator:	One to mount with 3" x 8" cylinder for adjustment on the go
Scrapers	Includes 3/16" x 6-1/2" x 8", high-carbon steel replaceable adjustable scraper blades mounted on bars of 2-1/2" x 2-1/2" square tubing. The scrapers are attached to the 2-1/2" x 1/2" thick arms with heavy-duty u-bolts	Main Frame	7" x 4" x 3/8" Toolbar with ASAE Cat. II and Cat. III hitch for quick coupler and conventional three point
Gang tilt	Hydraulically controlled-on-the-go adjustment	Bearings	Four Protect-O-Shield®, extra heavy duty 1-1/2" (38mm) square bore greasable ball type, toggle mounted, with zerk guards and wear guards
Hyd Cyl	One 3" x 8" and one 3-1/4" x 8" rephrasing cylinders to control tilt	Spacing	9" on LF6, 10-1/2" on LJ6
Hyd hoses	3/8" dia. Hoses to mount from hydraulic cylinders to tractor	Spacer Spools	Fabricated steel
Wrench	One for gang bolts	Transport Width	9'

MANUAL LEVEE PLOW

MODELS "MLF6" and "MLJ6"

9" or 10-1/2" Spacing

(F) & (J) series

STANDARD SPECIFICATIONS

(Metrics in Parentheses)

Axles	1-1/2" sq. high carbon cold rolled steel	Gang Angle:	18" to 28"
Blades	24" x 1/4" (6mm) Plain with 10" backup blade behind outside blades	Transport Width	9'
Scrapers	Includes 3/16" x 6-1/2" x 8", high-carbon steel replaceable adjustable scraper blades mounted on bars of 2-1/2" x 2-1/2" square tubing. The scrapers are attached to the 2-1/2" x 1/2" thick arms with heavy-duty u-bolts	Main Frame	7" x 4" x 3/8" Toolbar with ASAE Cat. II and Cat. III hitch for quick coupler and conventional three point
Gang tilt	Manually controlled	Bearings	Four Protect-O-Shield®, extra heavy duty 1-1/2" (38mm) square bore greasable ball type, toggle mounted, with zerk guards and wear guards
Wrench	One for gang bolts	Spacing	9" on LF6, 10-1/2" on LJ6
		Spacer Spools	Fabricated steel

LEVEE PLOW COMPONENTS

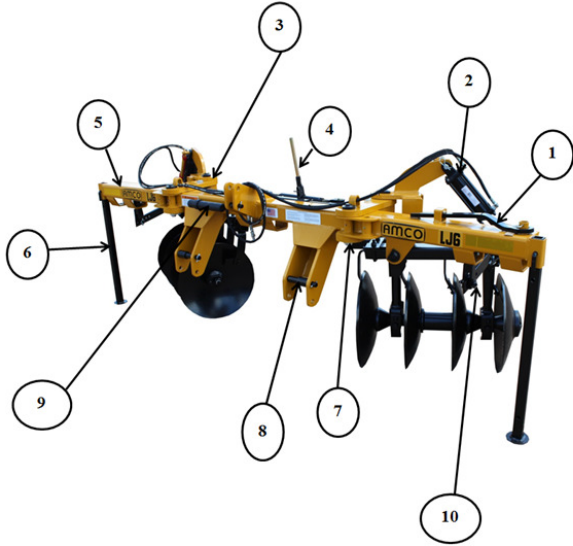

1. Gang bolt wrench
2. Manual ratchet jack or hydraulic cylinder for on-the-go gang tilt adjustment
3. Pivot bracket to allow the gangs to follow the levee
4. Ratchet for width adjustment
5. Main frame
6. Parking Stand
7. Pivot bracket port for wider setting
8. Cat II & III hitch pins placements
9. Manual tube
10. Gang cutting angle adjustment

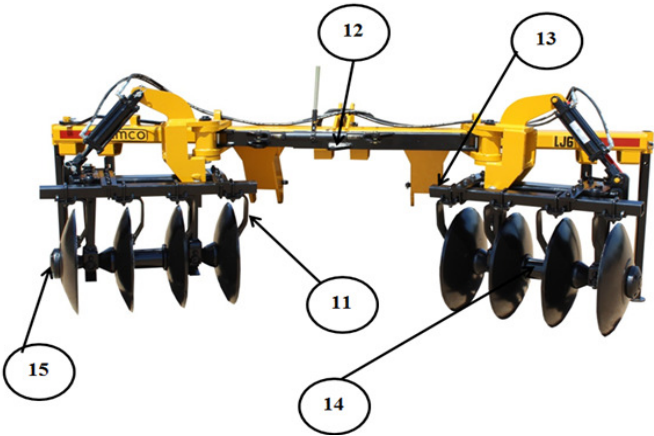

11. 2 1/2" x 1/2" thick scraper arms
12. Ratchet port for wider settings
13. 2 1/2" x 2 1/2" square tubing scraper rail
14. Welded steel spools for better durability
15. 1 1/2" square axle

HITCHING THE LEVEE PLOW TO THE TRACTOR

WARNING

Before dismounting from the tractor shut off the engine, set the parking brake and remove the key.

IMPORTANT

Using a 3-point quick hitch will make hitching and unhitching a one person operation plus add a measure of safety.

CAUTION

Do not stand or let anyone else let stand between the tractor and Levee Plow when hitching to it

1. Raise or lower tractor 3-point lift links as needed to match the lower Levee Plow hitch pin holes.

WARNING

Before dismounting from the tractor shut off the engine, set the parking brake and remove the key.

2. Attach the upper 3-point hitch adjusting link to the Levee Plow.
3. Slowly raise the Levee Plow. Watch for tractor and tractor tire interference.

WARNING

Before dismounting from the tractor shut off the engine, set the parking brake and remove the

4. Pin up the parking stands.
5. Adjust the upper 3-point hitch adjusting link so that top of the Levee Plow is level.

6. The tractor 3-point-draft control should be set in the float position.

UNHITCHING THE LEVEE PLOW FROM THE TRACTOR



WARNING

Before dismounting from the tractor shut off the engine, set the parking brake and remove the key.

1. Lower parking stands and securely pin into position.
2. Slowly lower the Levee Plow until the parking stands and Levee plow are on a firm level surface.



WARNING

Before dismounting from the tractor shut off the engine, set the parking brake and remove the key.

3. Unpin the tractor lift arms from the Levee Plow
4. Disconnect the upper 3-point hitch adjusting link from the Levee Plow
5. Carefully pull the tractor forward away from the levee plow

CHECKLIST BEFORE USING THE LEVEE PLOW



CAUTION

To insure safe steering at all times install proper ballast on the front of the tractor

1. Make sure the Levee Plow is properly attached to the tractor
2. Read and understand the operator's manual.
3. Read and familiarize yourself with the safety and warning decals on the Levee Plow.
4. Check all bolts to verify proper torque.



WARNING

Never operate the Levee Plow at excessive ground speed. Excessive ground speed can cause personal injury or damage to your tractor and Levee Plow!

5. Check the Levee Plow for parts that are broken or have excessive wear. If any are found replace them.
6. Check to make sure the tractor 3-point hitch is securely attached to the Levee Plow.
7. Verify the Levee Plow has been properly lubricated.

TRANSPORTATION



CAUTION

Always comply with all federal, state and local laws when traveling on public roads whether at night or during the day. Use accessory lights and devices for adequate warning to operators of other vehicles.

1. When raising the Levee Plow to transport, be sure the parking stands are pinned in the fully up position.
2. Raise the gangs for maximum ground clearance.
3. Be sure to reduce tractor ground speed when turning. Leave enough clearance so that the Levee Plow does not contact obstacles such as buildings, trees, or fences.
4. Select a safe ground travel speed when transporting from one area to another. When traveling on roadways, transport in such a way that faster moving vehicles may pass you safely.
5. When traveling over rough or hilly terrain, shift tractor to a lower gear.

MAINTENANCE & LUBRICATION



WARNING

Before making any adjustments, inspections, lubricating or repairing. Slowly lower the Levee Plow until it is firmly in contact with the ground. Before dismounting from the tractor shut off the engine set the parking brake and remove the key.



CAUTION

Never clean, adjust or service when the Levee Plow is in motion. Block up all elevated components to prevent accidental lowering or lower to rest on the ground when adjusting or repairing.



WARNING

Replace any missing, illegible or damaged safety decals!

Careful and regular attention to lubrication will greatly increase the life of the Levee Plow. For economical and efficient operation, proper lubrication of the gang hearings, pivot bracket pins, and ratchet jack is necessary. Be sure the grease fittings are free of dirt or paint before using the grease gun. Replace any damaged or missing fittings. Use a good grade of No.2 grease (lithium base). Never use greases which contain metallic additives. Always make sure that grease is clean and not contaminated with dirt or other foreign matter.

Lubrication Schedule

Grease weekly or after (50) hours of operation under normal conditions. It is recommended to grease at the beginning and end of each use season as well.

1. Gang Bearings.

Protect-O-Shield bearings should be greased until grease “pops” out around the bearings. The bearing will thus be purged of any dirt or foreign matter. The Protect-O-Shield prevents any possibility of blown seals. The bearing will be purged of any dirt or foreign matter. The Protect-O-Shield prevents any possibility of blown seals.

Special notice: Daily greasing may be necessary under extreme conditions such as in wet ground, during hot dry weather or when operating at high speeds.

2. Pivot Bracket Pins
3. Ratchet Jack

LEVEE PLOW EXTENDED STORAGE



CAUTION

Raise the Levee Plow high enough so both parking stands can be securely pinned to prevent the Levee Plow from falling forward while unhitching or in storage. Before dismounting from the tractor shut off the engine set the parking brake and remove the key.

1. Before unhitching the Levee Plow from the tractor clean off any dirt or debris that may have accumulated on any of the moving parts. Scrape off any compacted dirt from the disc blades. Then use a power washer to clean the Levee Plow.
2. Thoroughly inspect the entire Levee Plow for missing, worn or damaged parts including decals. Repair or replace parts during the “off season” to assure dependable, trouble-free performance during the use season.
3. Lubricate the Levee Plow as detailed in the Maintenance & Lubrication section of this manual.
4. Apply a rust preventative protective coating to the disc blades. Do the same for any exposed hydraulic cylinder rods or completely retract the cylinder rods.
5. The Levee Plow should be stored on a solid flat surface in a dry location. It is best to store the plow inside a storage building. Doing so will reduce future maintenance requirements and prolong the life of the plow.
6. To complete unhitching from the tractor follow the instructions in the Unhitching From The Tractor section in this manual.

OPERATING INSTRUCTIONS



CAUTION

This operator's manual should be carefully and thoroughly read to enable the operator to care for and operate the plow properly. The right and left hand sides of the levee plow as used in these instructions are determined by standing at the rear of the plow and facing the direction of travel.

Refer to your tractor operator's manual for complete tractor operating instructions.



WARNING

Never operate the Levee Plow using excessive horsepower. Doing so can result in structural damage to the Levee Plow.



CAUTION

Never tilt the Levee Plow forwards or backwards. Operating the Levee Plow tilted forward or backward will result in excessive blade wear. Plus, it will increase horsepower requirements.

HITCH: The AMCO Levee Plow is designed to hitch to ASAE Standard Category II and III three point hitches and to ASAE Standard Category II and III quick couplers. Simple pin to the appropriate holes using the spacers provided.

PARKING STANDS: Adjustable parking stands are provided as standard equipment. The stands should be raised and pinned for transport or field work. The stands should always be lowered and pinned to prevent the Levee Plow from falling forward while unhitching or while in storage. The Levee Plow should be parked on level ground to prevent the possibility of a tip over.

LEVEE PLOW OPERATING AND ADJUSTMENT INSTRUCTIONS

This operator's manual should be carefully and thoroughly read to enable the operator to care for and operate the plow properly. The right and left hand sides of the levee plow as used in these instructions are determined by standing at the rear of the plow and facing the direction of travel.

Refer to your tractor operator's manual for complete tractor operating instructions.



After parking the Levee Plow, always check to make sure that it cannot be overturned accidentally forwards or backwards.

LEVEE PLOW ADJUSTMENTS:

The AMCO Levee Plow can be easily adapted to create a levee tailored to your needs. Simple adjustments can be made to control the width and pitch of the levee. Adjustments can be made to determine the size of the borrow furrow or to eliminate the borrow furrow. Also the cutting depth, cutting angle and number of passes used will affect the resulting levee. The following instructions are provided to aid you in selecting the adjustment and means of operation that will best suit your needs.

GANG ANGLE ADJUSTMENT:

The gangs may be set at cutting angles from 18 degrees to 28 degrees depending on the need. Under normal conditions a setting somewhere between the extremes is advisable for best operation. More cutting angle will move the soil further and generally will improve penetration. Less angle will reduce the occurrence of large clods and will generally reduce "balling up" in wet soil conditions.

To decrease gang angle when in the levee building position, remove the angle adjusting pins underneath the ends of the main frame, shift the gangs forward and replace the pins at the desired setting. Make sure both gangs are pinned off at the same hole location. To increase gang angle move the gangs rearward. When in the levee-tear down position the angle adjusting links will be pinned at the middle of the plow underneath the main frame.

CUTTING WIDTH:

Use the ratchet jack on the Levee Plow side links to adjust cutting width. This will determine the overall width of the levee. Use the lower mounting lugs for 8-blade plows and the upper mounting lugs for 10-blade plows.

Gang Tilt ADJUSTMENT:

Vertical gang tilt plays a very important roll in levee construction. For this reason, the AMCO Levee Plow is designed for "on the go" tilt adjustment. The gangs may be simultaneously tilted hydraulically from the tractor seat. A tilt indicator numbered to show hydraulic cylinder stroke is provided on the right hand gang which enables the operator to know exactly how much the gangs are tilted. Once a desirable sequence of settings for levee construction is obtained, it is no problem to duplicate the same sequence using the numbers on the indicator. When encountering wet soil, gang tilt can be reduced "on the go" to help prevent the gangs from balling up. Refer to the suggestions on hydraulic circuit trouble shooting as well as hydraulic assembly (page 23).

LEVEE CONSTRUCTION INSTRUCTIONS

Depending on field conditions and management preference, different methods may be used for levee construction. Points to remember when constructing levees:

1. Avoid plowing up large clods on the first pass by limiting depth of cut. The core of the levee should consist of fine soil particles to prevent water seepage.
2. Generally it is best to allow time for the soil to dry between passes. This will help in pulverizing the soil, thereby avoiding large clods which make a porous levee and a poor seed bed for rice planted on the levee.
3. Under normal conditions, no more than 3 passes will be required to form a levee. Depending on soil conditions and the depth of water to be held, a levee may require only one pass.
4. During the first pass the two middle disc blades do most of the work of forming the levee. By limiting gang tilt and primarily using the middle blades on subsequent passes a narrow, steep sloped levee can be built with a shallow borrow furrow on the sides. Here again, using the proper gang tilt for subsequent passes is important.
5. An optional feathering blade kit is available for AMCO Levee Plows to reduce the effects of a steep borrow furrow.
6. Sometimes a burrow furrow is desirable to aid in draining the rice fields.
7. Sometimes it is good to pack the center of the levee with one or two passes of the tractor wheels to provide an impervious core before making the final pass.

LEVEE TEAR DOWN SETTINGS INSTRUCTIONS

For audio visual instructions

<https://www.youtube.com/watch?v=ab3YLCPJvIc>



WARNING

On all models of Levee Plows when reversing gangs to tear down levees, bearing wear guards must also be reversed. Failure to do so will cause soil/material buildup between the bearing and wear guard which could result in damage or component failure of both the wear guard and bearing riser.

The AMCO Levee Plow can be easily converted for tearing down levees as described in the following steps.

STEP 1

Remove left hand and right hand scraper bars

STEP 2

Remove adjusting links and mount on rear of mount bracket on gang frames.

STEP 3

Remove link anchor from the left hand and right hand holders, underneath the outside of the main frame, and insert the holders underneath the center of main frame.

STEP 4

Swing gang around and lock adjusting links in link anchors underneath center of main frame.

STEP 5

At this point it may be required to adjust the inner and outer slide links to get desired cutting angle.

STEP 6

Take the left hand scraper bar and put on the right hand gang. Take the second scraper and scraper bolt from right side of scraper bar off and insert a 5/8 x2-1/2 carriage bolt through the scraper, scraper bar and scraper has support and tighten securely.

STEP 7

Take right hand scraper bar and put on left hand gang. Take the second scraper and scraper bolt from right side of scraper bar off and insert the 5/8 x 2-1/2 carriage bolt through the scraper, scraper bar and scraper bar support and securely tighten. Next, the wear guards located at the bottom of the bearing risers will need to be reversed.

Note: Keep the two 5/8 x 1-3/4 carriage bolts that were removed from the scrapers in a safe place for use when returning the plow to the levee building position.

Be sure to check torque on all bolts and see that pins are properly fastened. Check scraper location to insure proper operation.

Adjust the ratchet jack so that bumper washers between the two gangs do not hit in the field. This will cause excessive wear and damage to the washers and gang axle. The hydraulic cylinders should be extended slightly to level the gangs. (Set gauges on 1.)

HYDRAULIC SYSTEM TROUBLE SHOOTING



WARNING

Hydraulic systems are highly pressurized. Escaping hydraulic oil, even an invisible pinhole leak can penetrate body tissues causing serious injury. Use a piece of wood or cardboard when looking for leaks-never use hands or parts of the body.



CAUTION

Relieve hydraulic pressure before disconnecting circuits. When reassembling make absolutely certain that all connections are tight.



CAUTION

If injured by hydraulic oil escaping under pressure, see a doctor immediately. Serious infection or reaction may occur if medical attention is not given at once.

When first hooking up the hydraulic hoses to the tractor, the hydraulic cylinder rods should be fully extended, and the hydraulic valve on the tractor should be held open for at least one minute. This operation will fill the hydraulic cylinders and hoses with hydraulic fluid. Check the tractor hydraulic fluid level afterward, since the levee plow cylinders and hoses hold three quarts of fluid. Retract and extend the cylinders several times to purge the system of air.

Should the cylinders fail to operate together, “check the hose installation as shown on page 23. The hose from the rod end of the 3-1/4” cylinder should connect to the butt end of the 3” cylinder.

It may be necessary to rephrase the hydraulic cylinders during field use. The two cylinders can get out of phase if fluid leaks out of the system, and the gangs will not work together. Should this occur, fully extend or fully retract the cylinders holding the tractor hydraulic valve open for a few seconds. This will allow additional fluid to pass through the system replacing any fluid that may have leaked out. By occasionally, either fully retracting or fully extending the cylinders during field use, the system will be rephrased continually thereby assuring that the gangs work together.

OPERATING TIPS



WARNING

Never operate the Levee Plow at excessive ground speed. Excessive ground speed can cause personal injury or damage to your tractor or Levee Plow!



WARNING

Never operate the Levee Plow using excessive horsepower. Doing so can result in structural damage to the Levee Plow.



CAUTION

1. Never allow unsafe conditions or operating practices. Your safety is of prime importance.
2. Raise the Levee Plow by the 3 point hitch when turning around. Failure to do so will result in broken blades, bent axles, and excessive strain on the hitch and main frame.
3. Reduce operating speed in any areas containing stumps, rocks or other obstacles.
Avoid plowing up large clods on the first pass by limiting the depth of the cut. The core of

- the levee should consist of fine soil particles to prevent water seepage.
4. Allow time for the soil to dry between passes unless it's unavoidable. Dry soil facilitates pulverizing large clods, which make a porous levee and a poor seedbed for rice planted on the levee.
 5. Make the right number of passes. Under normal conditions, no more than three passes will be required to form a levee. Depending on soil conditions and the depth of water to be held, a levee may require only one pass.
 6. Use the proper gang-tilt angle for all passes. During the first pass the two middle disc blades do most of the work of forming the levee. By limiting gang tilt and primarily using the middle blades on subsequent passes, a narrow, steeply slopped levee can be built with a shallow borrow furrow on the sides (a borrow furrow is formed when nearby soil is "borrowed" to build the levee).
 7. Install the optional feathering blade kit to reduce the effects of a steep borrow furrow.
 8. Leverage the burrow furrow. It can be used as a channel to help drain the rice field.
 9. Consider center packing. It can be an effective way to pack the center of the levee with one or two passes of the tractor wheels to provide an impervious core before making the final pass.

ASSEMBLY INSTRUCTIONS

The Levee Plow is shipped from the factory with maximum pre-assembly in the following bundles:

- A. Main Frame
- B. Two gang and frame bundles with scrapers and scraper bars attached
- C. Hydraulic cylinders and hoses

Place all bundles where they will be convenient. Arrange loose parts so they may be readily seen when needed. To insure good alignment of the units and parts, always insert all bolts leaving the nuts loose. Tighten the nuts evenly to prevent misalignment, distortion or binding. Be sure all bolts are tight, all cotter pins properly spread and all pins properly inserted.



CAUTION

Use sturdy assembly stands with the correct weight load bearing capability. Secure the main frame to the assembly stands 37" high.

STEP 1

Select clean level area for assembly. Place parking stands in main frame. Set main frame on assembly stands 37" high. Secure the main frame to the assembly stands.

STEP 2

Attach the pivot brackets to the two inside holes in the main frame for an eight blade gang and to the two outside holes for a ten blade gang. Use the 1-1/4" x 8-7/8" pins. Attach the angle brackets to the pivot brackets by the 1-1/4" x 11-1/8" pins.



Pivot bracket pin holes

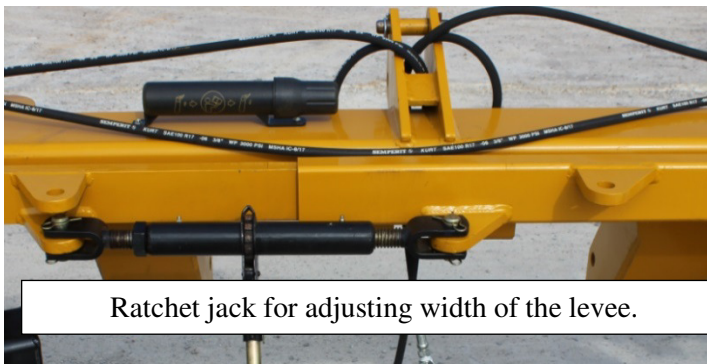

Ratchet jack for adjusting width of the levee.

STEP 3

Connect in and outer slide links to angle brackets by the 1 x 8 bolts. Now, attach the ratchet jack to the inner and outer slide links. Install in the top holes for the ten blade gang and in the bottom holes for an eight blade gang.

STEP 4

Attach gangs and frames to angle bracket by the 1-1/4" x 10-1/8" pin. Connect adjusting link to mount on gang frame and to the link anchor on the main frame.



Adjustment link for changing gang angle

STEP 5

Install a 3" x 8" hydraulic cylinder on the right hand gang; connect to angle bracket. Install a 3-1/4" x 8" hydraulic cylinder on the left hand gang; connect to angle bracket. Make sure the butt end of each cylinder is connected to the angle brackets and the rod end attached to the gang frames. Install the depth indicator on the 3' x 8" cylinder and secure with roll pins.



CAUTION

Hydraulic systems are highly pressurized. Escaping hydraulic oil, even an invisible pinhole leak can penetrate body tissues causing serious injury. Use a piece of wood or cardboard when looking for leaks-never use hands or parts of the body.



CAUTION

Relieve hydraulic pressure before disconnecting circuits. When reassembling make absolutely certain that all connections are tight.



CAUTION

If injured by hydraulic oil escaping under pressure, see a doctor immediately. Serious infection or reaction may occur if medical attention is not given at once.

STEP 6

Install hydraulic fittings and hoses as follows:

- (A) Install four #10921 1/2 male to 1/2 female swivel elbows into the ports on the 3-1/4" x 8" and 3" x 8" hydraulic cylinders. Turn fittings as shown in photo. Coat fittings with sealant before installation. Do not apply sealant over end of the fitting. This will keep the sealant out of the tractor hydraulic system. Tighten fittings!
- (B) Connect cylinders with hoses. Lay the hoses out where they will be readily accessible. Connect hoses and fittings as follows:
 - (1) The #11309 3/8" x 144" hose connects the rod end of the 3-1/4" x 8" to the butt end of the 3" x 8" cylinder. Route hoses through supports.
 - (2) The two #11307 3/8" x 120" hoses are used to connect the butt end of the 3-1/4" x 8"



Hydraulic 10 blade gang with feathering blades

cylinder & the rod end of the 3" x 8" cylinder to the tractor. Route hoses through the support brackets.

Manual Levee Plow Parts Diagram

This completes assembly of the hydraulic circuit for gang tilt. Carefully check your assembly and hose routing. All hoses must be routed through the support brackets to prevent damage.

STEP 7

Final grooming and check points:

- (A) Check all bolts for proper torque.
- (B) Check scraper adjustment. Scrapers should be adjusted to run 1/4" from disc blades
- (C) Check all hydraulic hoses and fittings for leaks. Repair as required. Replace fittings that continue to leak after tightening.
- (D) Lubrication for plow; Raise Levee Plow to transport position. Use a good grade of clean Lithium soap base chassis grease to grease the entire Levee Plow.
- (E) Grease the Levee Plow as follows:
 - (1) Grease all pivot pins until grease appears
 - (2) Grease the fitting on the ratchet jack
 - (3) Grease the gang bearings with 4 or 5 shots of grease to purge any condensation that has accumulated during shipment and storage. If the harrow is in storage for four to six months, the entire plow should again be lubricated before placing in service. It should be greased every 50 hours while in use, at the end of each season and at the start of each season.

PARTS LIST SELECTION

Main Frame Parts List

ITEM	PART NO.	DESCRIPTION	QTY
1	0388	RETAINER PIN W.A.	2
2	6670	Bushing	1
3	10228	1-8 X 4-1/2 HHCS GR 5 ZP	2
4	10317	KLK PIN 1/4"	7
5	10367	1 1/4-7 NC ALL METAL TOP LN GR C Z	4
6	10500	3/8-16 LOCK HEX NUT ZP	2
7	10663	1x8 NC HEX CAP SCREW GRADE 5 ZINC	2
8	10803	HAIR PIN - #10	1
9	10866	1-8 LOCK HEX NUT	4
10	10971	3/8-16 X 3 HHCS GR 5 ZP	2
11	10910	5/16 X 2 1/4 ROLL PIN ZP	3
12	11713	SERIAL PLATE	1
13	11714	DRIVE SCREW (TYPE "U") 6 GA. X .313"	2
14	12156	1/4-28 ZERK STRAIGHT SELF-TAP, H1641	4
15	12452	1-1/2-8 NYLON JAM NUT ZP	2
16	20136	PIN W.A.	2
17	20154	MAIN FRAME W.A.	1
18	20160	INNER SLIDE LINK W.A.	1
19	20161	OUTER SLIDE LINK W.A.	1
20	20164	ADJUSTING LINK W.A.	2
21	20165	LINK ANCHOR W.A.	2
22	20823	PIVOT BRACKET W.A. LH	1
23	20824	PIVOT BRACKET W.A. RH	1
24	20826	ANGLE BRACKET	2
25	20826	PIN W.A.	2
26	100134	NUT WRENCH	1
27	100540	BUSHING	4
28	100673	SPACER	2
29	100683	LOCK PIN	2
30	100758	LOWER HITCH PIN	2
31	101332	BUSHING	2
32	101333	PIN, UPPER HITCH	1
33	0942A	PIN	2
34	20166A	PARKING STAND ASSY	2

PIN LOCATIONS FOR PIVOT BRACKETS & LINKS
 "A" FOR 8 BLADE
 "B" FOR 10 & 12 BLADE

Hydraulic Levee Plow Parts List

COMES WITH PINS & CLIPS

LEFT HAND

RIGHT HAND

CONNECTION SIDE

RIGHT HAND

LEFT HAND

RIGHT SIDE
CYL WITH DEPTH GAGE

SCALE 0.150

PIN LOCATIONS FOR
PIVOT BRACKETS & LINKS
"A" FOR 8 BLADE
"B" FOR 10 & 12 BLADE

NOTE:
GANG FRAMES (LH & RH) ADDED FOR
CONNECTION CLARITY ONLY.

ITEM	PART NO.	DESCRIPTION	QTY
1	10856	5/16 X 1 1/2 ROLL PIN ZP	8
2	11494_EXT	RATCHET JACK @ 21.20" CL-CL	1
3	11682	TILT INDICATOR DECAL	1
4	12083	3 x 8 HYD CYL	1
5	12084	3 1/4 x 8 HYD CYL	1
6	12180	6901-08-08 #6 CRB M X #6 Fem Pipe Swvl, 90	4
7	19010	1/2" MALE QUICK DISCONNECT	2
8	20188	INDICATOR W.A.	1
9	101356	INDICATOR (MALE)	1
10	101440	PIN, SPECIAL	2
11	AD-01-0006	MAIN FRAME BUNDLE	1
12	11307	3/8 x 120 With 1/2 MPT FITTING HOSE	2
13	11309	3/8 x 144 With 1/2 MPT FITTING HOSE	1

Manual Levee Plow Parts List

ITEM	PART NO.	DESCRIPTION	QTY
1	11494_	RATCHET JACK @ 21.20" CL-CL	3
2	AD-01-0006	MAIN FRAME (BUNDLE)	1

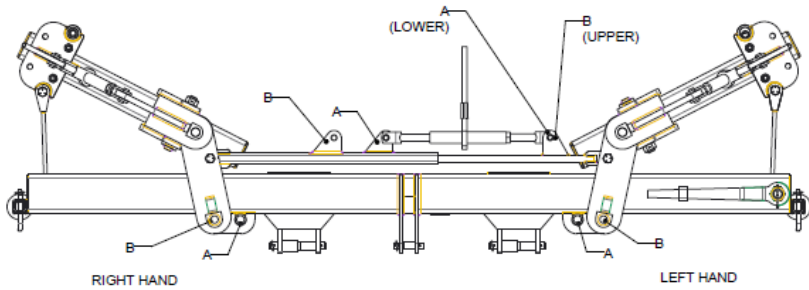
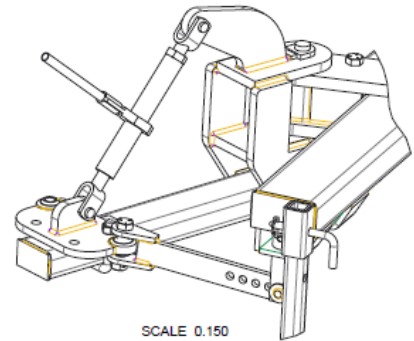
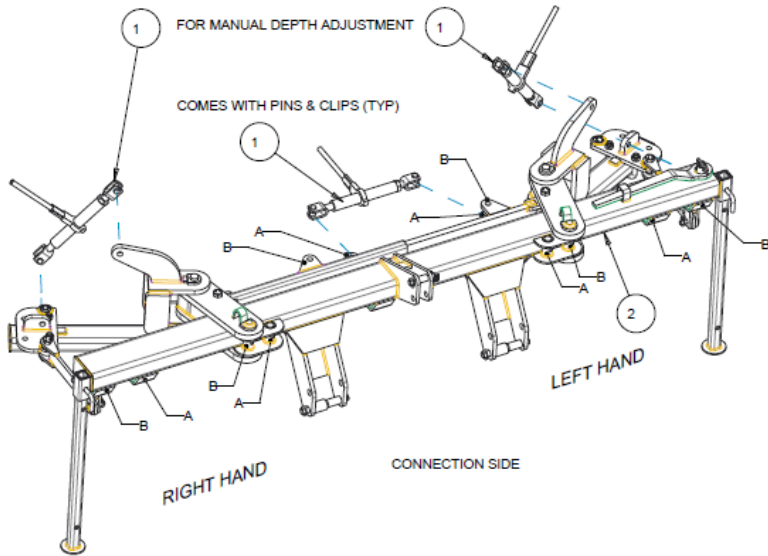

PIN LOCATIONS FOR
PIVOT BRACKETS & LINKS
"A" FOR 8 BLADE
"B" FOR 10 & 12 BLADE

NOTE:
GANG FRAMES (LH & RH) ADDED FOR
CONNECTION CLARITY ONLY.

Gang and Frame Parts List

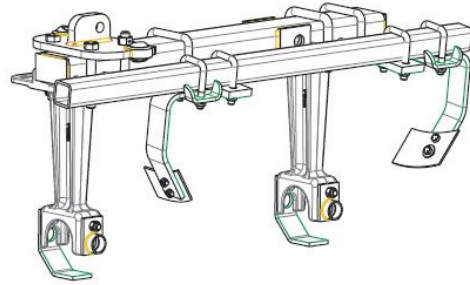
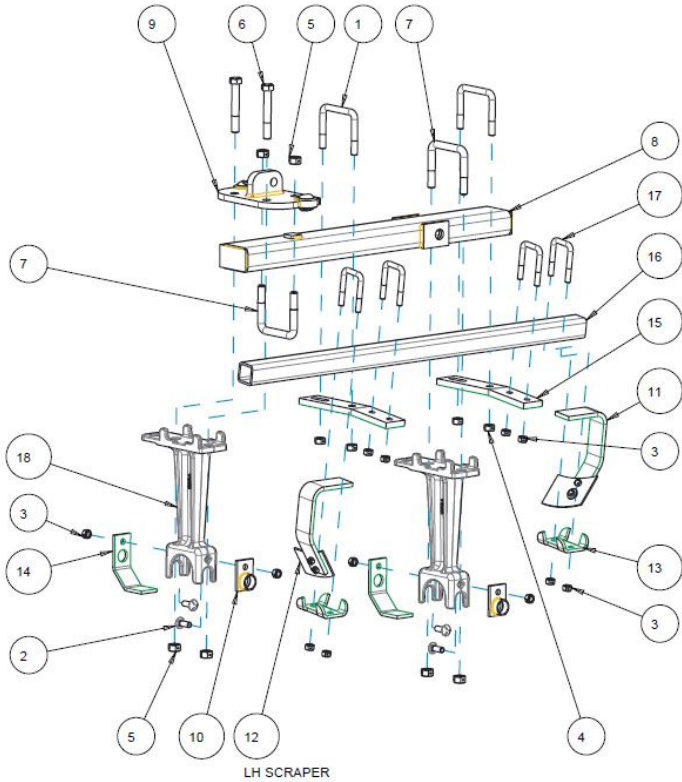

SCALE 0.150

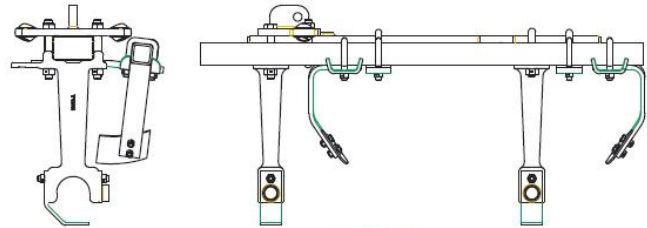

SCALE 0.125

ITEM NO.	PART NO.	DESCRIPTION	LF6 (9" spacing)			LJ6 (10.5" spacing)			
			TOTAL BLADE COUNT			TOTAL BLADE COUNT			
			8	10	12	8	10	12	10 TAPER
1	6513	3/4-10 U-BOLT	4	4	4	4	4	4	4
2	10135	5/8-11 X 1-3/4 CARRIAGE BOLT	4	4	4	4	4	4	4
3	10299	5/8-11 LOCK HEX NUT	34	36	38	34	36	38	36
4	10300	3/4-10 LOCK HEX NUT - TOP	8	8	8	8	8	8	8
5	10396	7/8-9 LOCK NUT - TOP	12	12	12	12	12	12	12
6	10591	7/8-9 X 6 HEX CAP SCREW	4	4	4	4	4	4	4
7	11280	7/8-9 U-BOLT	4	4	4	4	4	4	4
8	20155	GANG FRAME - WELDMENT	2			2			
8	20156	GANG FRAME - WELDMENT		2	2		2	2	2
9	20163	REAR MOUNT - WELDMENT	2	2	2	2	2	2	2
10	20579	GREASE ZERK GUARD - WELDMENT	4	4	4	4	4	4	4
11	21040	SCRAPER RH - ASSEMBLY	4	5	6	4	5	6	5
12	21041	SCRAPER LH - ASSEMBLY	4	5	6	4	5	6	5
13	101055	CLAMP BRACKET	8	10	12	8	10	12	10
14	102489	WEAR GUARD	4	4	4	4	4	4	4
15	103374	SCRAPER BAR SUPPORT	4	4	4	4	4	4	4
16	103478	SCRAPER BAR 2-1/2 SQ. TUBE		2	2		2	2	2
16	103479	SCRAPER BAR 2-1/2 SQ. TUBE	2			2			
17	100002A	5/8-11 U-BOLT	12	14	16	12	14	16	14
18	16012A	BEARING RISER	4	4	4	4	4	4	4

Levee Plow Gangs And Optional Feathering Blade Parts List

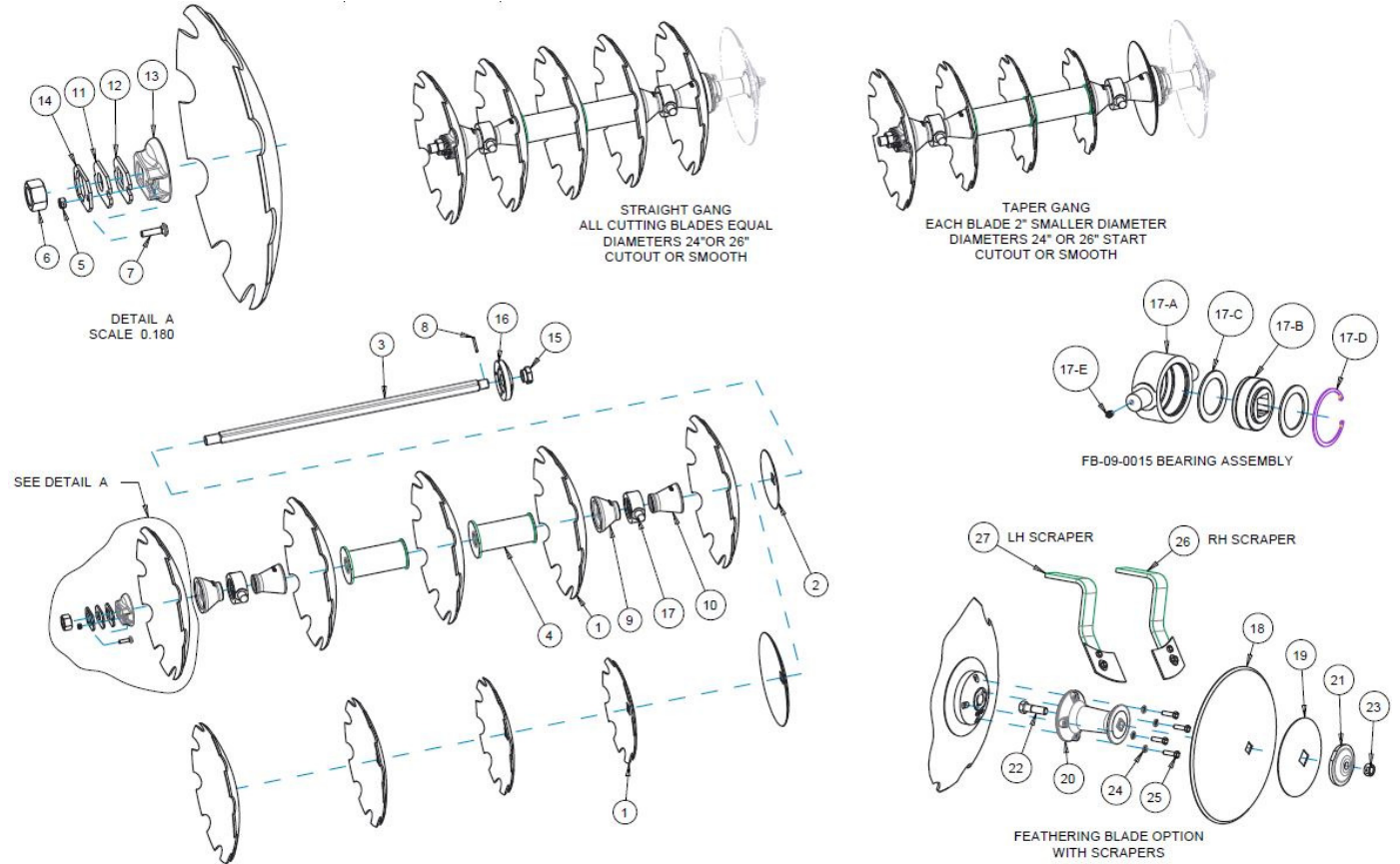

LF6 (9" spacing)

		LF6 24" DIA BLADES						LF6 26" DIA BLADES						
		SMOOTH BLADES			TOUT BLADES			SMOOTH BLADES			TOUT BLADES			
ITEM	PART NO	DESCRIPTION	BLADE COUNT			BLADE COUNT			BLADE COUNT			BLADE COUNT		
			8	10	12	8	10	12	8	10	12	8	10	12
1	2456	26 X 1/4 C.O. BLADE, 1-1/2 AXLE										8	10	12
1	3055	16 X 7 GA PLAIN BLADE, 1-1/2 AXLE												
1	3250	24 X 1/4 C.O. BLADE, 1-1/2 AXLE				8	10	12						
1	3255	24 X 1/4 PLAIN BLADE, 1-1/2 AXLE	8	10	12									
1	3263	26 X 1/4 PLAIN BLADE, 1-1/2 AXLE							8	10	12			
1	3275	22 X 1/4 C.O. BLADE, 1-1/2 AXLE												
1	3276	22 X 1/4 PLAIN BLADE, 1-1/2 AXLE												
1	9482	18 X 1/4 PLAIN BLADE, 1-1/2 AXLE												
1	11588	20 X 1/4 PLAIN BLADE, 1-1/2 AXLE												
1	11589	20 X 1/4 C.O. BLADE, 1-1/2 AXLE												
1	12219	18 X 1/4 C.O. BLADE, 1-1/2 AXLE												
2	3278	10" PLAIN BLADE, 1-1/2 AXLE	2	2	2	2	2	2	2	2	2	2	2	2
3	9440	1.50 x 33.625 SQUARE AXLE												
3	9441	1.50 x 43.125 SQUARE AXLE												
3	9442	1.50 x 52.375 SQUARE AXLE												
3	9449	1.50 x 38.75 SQUARE AXLE	2			2			2			2		
3	9450	1.50 x 49.50 SQUARE AXLE		2			2			2			2	
3	9451	1.50 x 60.25 SQUARE AXLE			2		2			2			2	
4	545	SPACER SPOOL - WELDMENT (9" LF6)	2	4	6	2	4	6	2	4	6	2	4	6
4	1296	SPACER SPOOL - WELDMENT (10.5" LJ6)												
5	10395	1/2-13 LOCK HEX NUT	2	2	2	2	2	2	2	2	2	2	2	2
6	10489	1 1/2-12 NF GRADE 8 HEX NUT	2	2	2	2	2	2	2	2	2	2	2	2
7	10710	1/2-13 X 2 CARRIAGE BOLT	2	2	2	2	2	2	2	2	2	2	2	2
8	11659	5/16 X 2 1/2 ROLL PIN	2	2	2	2	2	2	2	2	2	2	2	2
9	17006	END BELL, LARGE												
9	17008	END BELL, LARGE	4	4	4	4	4	4	4	4	4	4	4	4
10	17007	END BELL, SMALL	4	4	4	4	4	4	4	4	4	4	4	4
11	100098	BEARING PLATE	2	2	2	2	2	2	2	2	2	2	2	2
12	100099	SPACER PLATE (QTY MAY VARY PER	2	2	2	2	2	2	2	2	2	2	2	2
13	1222A	END WASHER	2	2	2	2	2	2	2	2	2	2	2	2
14	5622A	LOCK PLATE, NUT	2	2	2	2	2	2	2	2	2	2	2	2
15	9577B	NUT - GANG BOLT	2	2	2	2	2	2	2	2	2	2	2	2
16	9579A	BUMBER WASHER	2	2	2	2	2	2	2	2	2	2	2	2

		LF6 24" DIA BLADES						LF6 26" DIA BLADES						
		SMOOTH BLADES			TOUT BLADES			SMOOTH BLADES			TOUT BLADES			
ITEM	PART NO	DESCRIPTION	BLADE COUNT			BLADE COUNT			BLADE COUNT			BLADE COUNT		
			8	10	12	8	10	12	8	10	12	8	10	12
17	FB-09-001	BEARING HOUSING ASSEMBLY	4	4	4	4	4	4	4	4	4	4	4	4
17-A	16003	HOUSING - BEARING	4	4	4	4	4	4	4	4	4	4	4	4
17-B	11503	BEARING, 1 1/2 INCH SQUARE BORE	4	4	4	4	4	4	4	4	4	4	4	4
17-C	100104	WASHER	8	8	8	8	8	8	8	8	8	8	8	8
17-D	11064	SNAP RING	4	4	4	4	4	4	4	4	4	4	4	4
17-E	12384	1/8 NPT GREASE FITTING, STRT.	4	4	4	4	4	4	4	4	4	4	4	4
FEATHERING BLADE OPTION														
18	3262	20 X 3/16 PLAIN BLADE, 1-1/2 AXLE	2	2	2	2	2	2	2	2	2	2	2	2
19	3278	10" PLAIN BLADE, 1-1/2 AXLE	2	2	2	2	2	2	2	2	2	2	2	2
20	7673	FEATHERING BLADE SPACER	2	2	2	2	2	2	2	2	2	2	2	2
21	7801	BLADE CAP	2	2	2	2	2	2	2	2	2	2	2	2
22	10189	7/8-9 X 3 HEX CAP SCREW GRADE 8	2	2	2	2	2	2	2	2	2	2	2	2
23	10396	7/8-9 LOCK NUT - TOP	2	2	2	2	2	2	2	2	2	2	2	2
24	10886	1/2 SPLIT LOCK WASHER	8	8	8	8	8	8	8	8	8	8	8	8
25	10928	1/2-13 X 1-3/4 HEX CAP SCREW GRADE 8	8	8	8	8	8	8	8	8	8	8	8	8
26	103512	FEATHERING SCRAPER - RH	1	1	1	1	1	1	1	1	1	1	1	1
27	103513	FEATHERING SCRAPER - LH	1	1	1	1	1	1	1	1	1	1	1	1

LJ6 (10.5" spacing)

ITEM	PART NO	DESCRIPTION	LJ6 24" DIA BLADES								LJ6 26" DIA BLADES							
			SMOOTH BLADES				CUTOUT BLADES				SMOOTH BLADES				CUTOUT BLADES			
			BLADE COUNT				BLADE COUNT				BLADE COUNT				BLADE COUNT			
	8	10	12	10 TAPER	8	10	12	10 TAPER	8	10	12	10 TAPER	8	10	12	10 TAPER		
1	2456	26 X 1/4 C.O. BLADE, 1-1/2 AXLE																
1	3055	16 X 7 GA PLAIN BLADE, 1-1/2 AXLE				2				2								
1	3250	24 X 1/4 C.O. BLADE, 1-1/2 AXLE															2	
1	3255	24 X 1/4 PLAIN BLADE, 1-1/2 AXLE	8	10	12	2												
1	3263	26 X 1/4 PLAIN BLADE, 1-1/2 AXLE											8	10	12	2		
1	3275	22 X 1/4 C.O. BLADE, 1-1/2 AXLE															2	
1	3276	22 X 1/4 PLAIN BLADE, 1-1/2 AXLE				2									2			
1	9482	18 X 1/4 PLAIN BLADE, 1-1/2 AXLE				2									2			
1	11588	20 X 1/4 PLAIN BLADE, 1-1/2 AXLE				2									2			
1	11589	20 X 1/4 C.O. BLADE, 1-1/2 AXLE													2			
1	12219	18 X 1/4 C.O. BLADE, 1-1/2 AXLE															2	
2	3278	10" PLAIN BLADE, 1-1/2 AXLE	2	2	2	2	2	2	2	2	2	2	2	2	2	2	2	
3	9440	1.50 x 33.625 SQUARE AXLE	2						2				2					
3	9441	1.50 x 43.125 SQUARE AXLE		2					2					2				
3	9442	1.50 x 52.375 SQUARE AXLE			2											2		
3	9449	1.50 x 38.75 SQUARE AXLE															2	
3	9450	1.50 x 49.50 SQUARE AXLE																
3	9451	1.50 x 60.25 SQUARE AXLE																
4	545	SPACER SPOOL - WELDMNT (9" LF6)																
4	1296	SPACER SPOOL - WELDMNT (10.5" LJ6)	1	2	3	2			1	2	3	2			1	2	3	2
5	10395	1/2-13 LOCK HEX NUT	2	2	2	2	2	2	2	2	2	2	2	2	2	2	2	2
6	10489	1 1/2-12 NF GRADE 8 HEX NUT	2	2	2	2	2	2	2	2	2	2	2	2	2	2	2	2
7	10710	1/2-13 X 2 CARRIAGE BOLT	2	2	2	2	2	2	2	2	2	2	2	2	2	2	2	2
8	11659	5/16 X 2 1/2 ROLL PIN	2	2	2	2	2	2	2	2	2	2	2	2	2	2	2	2
9	17006	END BELL, LARGE	4	4	4	4	4	4	4	4	4	4	4	4	4	4	4	4
9	17008	END BELL, LARGE																
10	17007	END BELL, SMALL	4	4	4	4	4	4	4	4	4	4	4	4	4	4	4	4
11	100098	BEARING PLATE	2	2	2	2	2	2	2	2	2	2	2	2	2	2	2	2
12	100099	SPACER PLATE (QTY MAY VARY PER A)	2	2	2	2	2	2	2	2	2	2	2	2	2	2	2	2
13	1222A	END WASHER	2	2	2	2	2	2	2	2	2	2	2	2	2	2	2	2
14	5622A	LOCK PLATE, NUT	2	2	2	2	2	2	2	2	2	2	2	2	2	2	2	2
15	9577B	NUT - GANG BOLT	2	2	2	2	2	2	2	2	2	2	2	2	2	2	2	2
16	9579A	BUMBER WASHER	2	2	2	2	2	2	2	2	2	2	2	2	2	2	2	2

ITEM	PART NO	DESCRIPTION	LJ6 24" DIA BLADES								LJ6 26" DIA BLADES							
			SMOOTH BLADES				CUTOUT BLADES				SMOOTH BLADES				CUTOUT BLADES			
			BLADE COUNT				BLADE COUNT				BLADE COUNT				BLADE COUNT			
	8	10	12	10 TAPER	8	10	12	10 TAPER	8	10	12	10 TAPER	8	10	12	10 TAPER		
17	FB-09-001	BEARING HOUSING ASSEMBLY	4	4	4	4	4	4	4	4	4	4	4	4	4	4	4	4
17-A	16003	HOUSING - BEARING	4	4	4	4	4	4	4	4	4	4	4	4	4	4	4	4
17-B	11503	BEARING, 1 1/2 INCH SQUARE BORE	4	4	4	4	4	4	4	4	4	4	4	4	4	4	4	4
17-C	100104	WASHER	8	8	8	8	8	8	8	8	8	8	8	8	8	8	8	8
17-D	11064	SNAP RING	4	4	4	4	4	4	4	4	4	4	4	4	4	4	4	4
17-E	12384	1/8 NPT GREASE FITTING, STRT.	4	4	4	4	4	4	4	4	4	4	4	4	4	4	4	4
FEATHERING BLADE OPTION																		
18	3262	20 X 3/16 PLAIN BLADE, 1-1/2 AXLE	2	2	2	2	2	2	2	2	2	2	2	2	2	2	2	2
19	3278	10" PLAIN BLADE, 1-1/2 AXLE	2	2	2	2	2	2	2	2	2	2	2	2	2	2	2	2
20	7673	FEATHERING BLADE SPACER	2	2	2	2	2	2	2	2	2	2	2	2	2	2	2	2
21	7801	BLADE CAP	2	2	2	2	2	2	2	2	2	2	2	2	2	2	2	2
22	10189	7/8-9 X 3 HEX CAP SCREW GRADE 8	2	2	2	2	2	2	2	2	2	2	2	2	2	2	2	2
23	10396	7/8-9 LOCK NUT - TOP	2	2	2	2	2	2	2	2	2	2	2	2	2	2	2	2
24	10886	1/2 SPLIT LOCK WASHER	8	8	8	8	8	8	8	8	8	8	8	8	8	8	8	8
25	10928	1/2-13 X 1-3/4 HEX CAP SCREW GRADE 8	8	8	8	8	8	8	8	8	8	8	8	8	8	8	8	8
26	103512	FEATHERING SCRAPER - RH	1	1	1	1	1	1	1	1	1	1	1	1	1	1	1	1
27	103513	FEATHERING SCRAPER - LH	1	1	1	1	1	1	1	1	1	1	1	1	1	1	1	1

TROUBLESHOOTING GUIDE

Problem	Solution
Levee plow is pulling to one side (Manual levee plow with ratchets)	One side of the levee plow is set deeper than the other. Find level ground and make sure both sides match evenly.
Levee plow is pulling to one side (Hydraulic)	Fully raise 3-point hitch. Then fully lower and raise your level plow arm to reset your phasing cylinder - repeat 3 times.
Bearing risers breaking	If wear guards are not reversed when levee plow is in teardown position it can cause bearing risers to break
Levee plow is not holding down pressure	<p>Fully raise then fully lower your phasing cylinder – repeat 3 times.</p> <p>Inspect for hydraulic leaks</p> <p>If leads are not found unplug hydraulic lines from tractor to determine if the problem is the tractor or the plow</p> <p>If problem persists you could have air in your hydraulic line</p> <p>If the problem is still present then you will need to determine what cylinder is not holding pressure</p>