



AD-540-OS ** AD-540-V ** AD-1000-OS **

AD-1000-V

AMCO DITCHER

**OPERATOR'S MANUAL
PART IDENTIFICATION**



OFFSET AND VERTICAL ROTARY DITCHERS

Revised 6/26/19

AMCO MANUFACTURING COMPANY

800 South Industrial Parkway • P.O. Box 1107

Yazoo City, Mississippi (MS) 39194 USA

(662) 746-4464 • Toll Free: (800) 748-9022 • Fax: (662) 746-6825

www.amcomfg.com

TABLE OF CONTENTS

Foreword.....	3
Safety.....	4
Specifications.....	5
Bolt Torque.....	6
Warning Decals.....	7
Vertical & Offset Ditcher Components.....	7
Tractor Horsepower Guidelines.....	8
Hitching the Ditcher to the Tractor.....	8
Proper PTO Shaft Alignment.....	9
Unhitching the Ditcher from the Tractor.....	10
Checklist before Using the Ditcher.....	10
Operating the Ditcher.....	11
Transportation.....	13
Maintenance & Lubrication.....	13
Drive Chain and Idler Sprocket Adjustment.....	14
Leveling the Ditcher.....	15
Flat & Concaved Skid Shoe Adjustment.....	16
Cutter Head & Cutting Blades.....	17
Ditcher Extended Storage.....	18
Troubleshooting Guide.....	19
AD-540-V.....	20-22
AD-1000-V.....	23-25
AD-540-OS.....	26-28
AD-1000-OS.....	29-31

FOREWORD

You've just joined an exclusive but rapidly growing club.

For our part, we want to welcome you to the group and thank you for buying an AMCO product.

We hope your new AMCO implement will help you achieve both increased productivity and increased efficiency so that you may generate more profit.

This operator's manual has been designed into five major sections: Foreword, Safety Precautions, Operation, Troubleshooting and Parts Identification.

It is important the owner/operator knows the implement model number and serial number. Write the serial and model number in the space provided and use it in all correspondence when referring to the implement.

Throughout the manual, references may be made to left side and right side. These terms are used as viewed from the operator's seat facing the front of the tractor.

This **SAFETY ALERT SYMBOL**



indicates important safety messages in the manual. When you see this symbol, be alert to the possibility of **PERSONAL INJURY** and carefully read the message that follows.

The word **NOTE** is used to convey information that is out of context with the manual text. It contains special information such as specifications,

techniques, reference information and other information of a supplementary nature.

The word **IMPORTANT** is used in the text when immediate damage will occur to the machine due to improper technique or operation. Important will apply to the same information as specified by **NOTE** only of an immediate and urgent nature.

It is the responsibility of the user to read the operator's manual and comply with the safe and correct operating procedure and to lubricate and maintain the product according to the maintenance schedule in the operator's manual.

The user is responsible for inspecting his machine and for having parts repaired or replaced when continued use of the product would cause damage or excessive wear to the other parts.

It is the user's responsibility to deliver his machine to the AMCO dealer who sold him the product for service or replacement of defective parts that are covered by the warranty policy.

If you are unable to understand or follow the instructions provided in the publication, consult your local AMCO dealer or contact:

AMCO MANUFACTURING, INC.

662-746-4464

800-748-9022

662-746-6825 (FAX)

Website: www.amcomfg.com

E-mail: sales@amcomfg.com
parts@amcomfg.com

AMCO Manufacturing warrants all products manufactured and sold by it against defects in material. This warranty being expressly limited to replacement at the factory of such parts or products as will appear to be defective after inspection.

This warranty does not obligate the Company to bear cost of labor in replacement of parts. It is the policy of the company to make improvements without incurring obligations to add them to any unit already sold. No warranty is made or authorized to be made, other than herein set forth. This warranty is in effect for one year after purchase.

Model Number: _____

Serial Number: _____

Dealer: _____

AMCO Manufacturing warrants its own products only and cannot be responsible for damage to equipment on which mounted.

SAFETY

A brief description of signal words that may be used in this manual:

CAUTION: Used as a general reminder of good safety practices or to direct attention to unsafe practices.

WARNING: Denotes a specific potential hazard.

DANGER: Denotes the most serious specific potential hazard.

SAFETY PRECAUTIONS

You can make your farm a safer place to live and work if you observe the safety precautions given. Study these precautions carefully and insist that they be followed by those working with you and for you.



WARNING

Never clean, lubricate or adjust a machine that is in motion. Always lower or block the implement before performing service.

If machine must be serviced in the raised position, jack or block it up to prevent it from accidentally falling and injuring someone.

Do not allow riders on the tractor or implement.

Use speeds and caution dictated by the terrain being traversed. Do not operate on any slope steep enough to cause tipping or loss of control.

Be sure all personnel are clear of the immediate area before operating.

Read and understand the operator's manual and require all other persons who will operate the equipment to do the same.

Be familiar with all tractor and implement controls and be prepared to stop engine and implements quickly in an emergency.



Consult your implement and tractor operator's manual for correct and safe operating practices.

Beware of towed implement width and allow safe clearance.

FAILURE TO HEED MAY RESULT IN PERSONAL INJURY OR DEATH.

SPECIFICATIONS

Model No.	Description	Approx Weight
	Vertical Ditchers (Body Only)	
AD-540-V	Vertical Rotary Ditcher for 540 PTO with Buster Shank	569 lbs.
AD-1000-V	Vertical Rotary Ditcher for 1000 PTO with Buster Shank	569 lbs.
	Offset Ditcher (Body Only)	
AD-540-OS	Left Offset Rotary Ditcher for 540 PTO with Buster Shank	734 lbs.
AD-1000-OS	Left Offset Rotary Ditcher for 1000 PTO with Buster Shank	734 lbs.
	Cutter Heads (5 Blades)	
AD-CHA18	Cutter Head 18" – 20" 5 Blade (Reversible for longer life)	72 lbs.
AD-CHA26	Cutter Head 24" – 26" 5 Blade (Reversible for longer life)	109 lbs.
	PTO Driveline	
AD-DL6S	1-3/8", 6 Spline 540 PTO	56 lbs.
AD-DL21S	1-3/8", 21 Spline 1000 PTO	56 lbs.
AD-DL20S	1-3/4", 20 Spline 1000 PTO	58 lbs.

DRIVELINE SHEAR BOLTS

- 1) Bondioli drivelines use a metric M10 bolt, grade 8.8 (equivalent to standard grade 5). The part numbers to use are 12320-1(bolt) & 10510 (nut).
- 2) Weasler, which is the current supplier, uses a standard 3/8-16 bolt, grade 5. The part numbers to use are 10764 (bolt) & 10509 (nut).

Formatted: Font: 20 pt, Font color: Auto

Formatted: Font: 20 pt, Font color: Auto

BOLT TORQUE



WARNING





Before making any adjustments, lubricating or repairing:

First, disengage the tractor's PTO and wait for the cutter head and cutting blades to come to a complete stop. Then slowly lower the ditcher until skid shoe is touching the ground. Before dismounting from the tractor shut off the engine set the parking brake and remove the key.

READ THESE INSTRUCTIONS FIRST:

1. Improperly tightened bolts will result in damage, breakage, expense, and down time.
2. Always replace bolts with the specified grade and type.
3. Torque properly before first use of the machine and every 2-4 hours of use until you are sure bolts are staying tight.
4. The chart below is a guide for proper torque. Use it unless a specified torque is called out elsewhere in the manual.
5. Torque is the force you apply to the wrench handle or the cheater bar, times the length of the handle or bar.
6. Use a torque wrench whenever possible.

The following table shows torque in ft. lbs.

BOLT DIA. AND THREADS PER INCH		 OR 	
	GRADE 2	GRADE 5 A-325	GRADE 8
3/8-16	25	35	50
7/16-14	35	55	80
1/2-13	55	85	125
9/16-12	75	125	175
5/8-11	105	170	235
3/4-10	185	305	425
7/8-9	170	445	690
1-8	260	670	1030
1 1/8-7	365	900	1460
1 1/4-7	515	1275	2060
1 3/8-6	675	1675	2700
1 1/2-6	900	2150	3500
1 3/4-5	1410	3500	5600

Shear Bolt Torque Rating

Metric bolt torque for M12 Class 8.8 zinc plated is 55.1 foot-pounds.

WARNING DECALS

Familiarize yourself with the warning decals affixed to the ditcher. It is important for you to operate the ditcher safely. Read and follow the safety directions on all warning decals.

1. For operator safety make sure all warning decals are clean and legible.
2. Immediately replace any damaged or missing warning decals.
3. Never cover or obscure a warning decal.
4. Refer to the Parts Identification Section of this manual for correct warning decal locations.
5. Replacement warning decals can be obtained from your AMCO Dealer or by contacting AMCO at amcomfg.com.

VERTICAL AND OFFSET DITCHER COMPONENTS

- | | |
|----------------------------|--------------------------------------|
| 1. PTO Shaft | 6. Buster Shank |
| 2. Chain Case | 7. Input and Output Shafts |
| 3. Concave Skid Shoe | 8. Reversible Ditcher Cutting Blades |
| 4. Ratchet Jack Adjustment | 9. Operator's Manual Storage Tube |
| 5. Parking Stand | 10. Serial Number Plate |

VERTICAL DITCHER

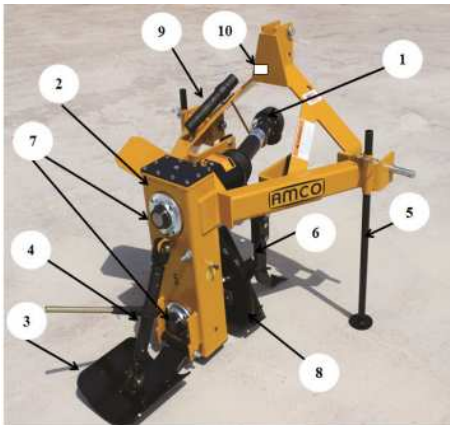

OFFSET DITCHER

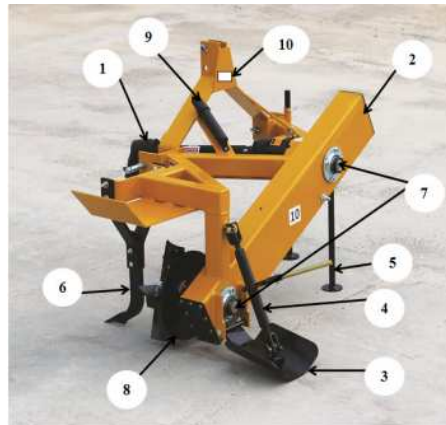

TRACTOR HORSEPOWER GUIDELINES



WARNING

Never operate the ditcher above its RPM rating; Excessive PTO speed can cause personal injury or damage to your tractor and ditcher.

All 540 RPM ditcher models are designed for use on tractors from 50 to 110 PTO horsepower.

All 1000 RPM ditcher models are designed for use on tractors from 80 to 150 PTO horsepower.

HITCHING THE DITCHER TO THE TRACTOR

1. Before backing the tractor in front of the ditcher, check the PTO shaft travel. The PTO shaft must slide freely forward and must not bottom out. If the PTO shaft doesn't slide freely or bottoms out, damage to the bearings and shaft may occur.
2. Lubricate the PTO shaft per the instructions in the Maintenance & Lubrication Section of this manual.
3. Check the shearbolt.
4. Make sure tractor drawbar is moved to one side, retracted or removed.



CAUTION

Make sure the tractor drawbar is moved to one side, retracted or removed. Do not leave the drawbar in the middle of the tractor as damage may occur to the PTO shaft.

5. The ditcher will fit Category II and III three point hitches or Category II quick coupler. Careful attention should be given to mounting the ditcher to the tractor. The three tractor lift links should be connected to the ditcher with the connecting pins. The PTO shaft should be connected to the tractor PTO shaft by slipping the shaft forward until the quick disconnect pin slips into the groove on the tractor PTO shaft. Periodic cleaning and a few drops of oil on the splined surfaces and on the quick disconnect pin will simplify this operation. Be careful, the universal drive shaft could slip off the tractor PTO shaft if the quick disconnect pin is not properly seated.
6. The parking stands should be raised and pinned in the raised position. The ditcher should be slowly raised and lowered to check the drive shaft length. At least 6" of the shaft should be engaged in the tubular portion of the universal drive shaft. Check the drive shaft in the fully retracted position to make sure it is not binding and will turn freely. Also check to be sure the drive shaft will not hit the tractor drawbar.

- The tractor's top lift link should be extended or retracted until the chain case is vertical when lowered to the normal operating position. The universal drive shaft must have an equal offset in each joint (see photo in Proper PTO Shaft Alignment section in this manual). As an example, if the front joint is offset 6 degrees the rear joint must also have a 6 degree offset. Should the rear joint be offset 4 degrees or 8 degrees the cutter head will not run at a constant speed and will vibrate excessively. Operating the ditcher in this condition will cause drive shaft, shear bolt and chain failures.

PROPER PTO SHAFT ALIGNMENT

The tractor's top lift link should be extended or retracted until the chain case is vertical when lowered to the normal operating position. The drive line must have an equal offset in each joint. See photo below. As an example, if the front joint is offset 4 degrees or 8 degrees, the cutter head will not run at a constant speed and will vibrate excessively. Operating the Ditcher in this condition will cause drive line, shear bolt, and chain failures.

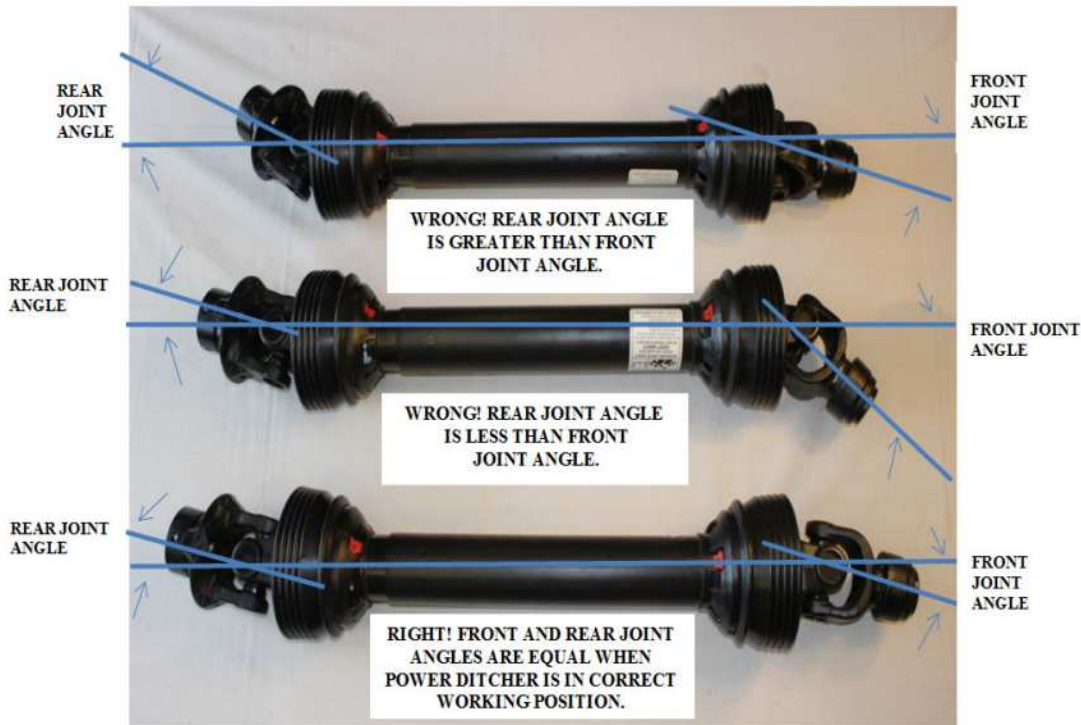

UNHITCHING THE DITCHER FROM THE TRACTOR



WARNING

Before dismounting from the tractor shut off the engine set the parking brake and remove the key.

1. Prior to unhitching the ditcher from the tractor at the end of the use season or for an extended period of time review the Extended Ditcher Storage Recommendations Section of this manual.
2. Raise the ditcher high enough so the skid shoe can be adjusted and both parking stands can be secured in the holes that match the size of the cutter head.
3. Lower both parking stands to the selected height based on the cutter head diameter and install the hair pins to lock both stands in place. Double check to make sure both parking stands are securely in place. Adjust the skid shoe as needed for Step 4.
4. Slowly lower the ditcher until the skid shoe and both parking stands have come in contact with a firm flat surface. The buster shank and cutter head should be slightly above ground level.
5. Disconnect the PTO shaft safety chain from tractor.
6. Pull back on the tractor end PTO shaft yoke collar and hold while sliding the PTO shaft yoke collar off of the tractor PTO shaft.
7. Place the yoke end of the PTO shaft in the PTO hanger attached to the side of the ditcher 3-point hitch. Ditchers built prior to **June 1, 2015** hold the yoke end under the upper 3-point hitch pin and secure it in place with a length of chain and klik pins.
8. Remove the klik pin and pin connecting the tractor 3-point center link to the ditcher. Place the tractor 3-point center link into its storage position.
9. Remove lower 3-point klik pins and hitch pins from lower 3-point clevises.
10. Lower the 3-point lift arms below the clevises.
11. Use care while driving the tractor away from ditcher make sure the lower 3-point lift arms are free from the ditcher and do not pull against it.
12. Pull the tractor away from the ditcher. Before dismounting the tractor shut off the engine set the parking brake and remove the key. Reinstall the ditcher 3-point hitch pins, bushing, and klik pins.

CHECKLIST BEFORE USING THE DITCHER



CAUTION

Make sure the tractor drawbar is moved to one side, retracted or removed. Do not leave the drawbar in the middle of the tractor as damage may occur to the PTO shaft.

1. Make sure the ditcher is properly attached to the tractor

2. Read and understand the operator's manual.
3. Read and familiarize yourself with the safety and warning decals on the ditcher.
4. Check all bolts to verify proper torque.
5. Level the chain case. See the LEVELING THE DITCHER SECTION of this manual



WARNING

Never operate the ditcher above its RPM rating; Excessive PTO speed can cause personal injury or damage to your tractor and ditcher!

6. Check the ditcher for parts that are broken or have excessive wear. If any are found replace them.
7. Check to make sure the tractor 3-point hitch is securely attached to the ditcher.
8. Verify the ditcher has been properly lubricated.
9. Check the chain case oil level. This is done by removing the check plug on the side of the chain case. The oil level should be level with the bottom of the plug hole.
10. Adjust the skid shoe to the initial depth setting as detailed in the Flat and Concaved Skid Shoe section of this manual.
11. Verify the PTO shaft is firmly connected to the tractor.
12. Slowly raise and lower the ditcher to check the engagement of the PTO shaft. There should be at least 6" of engagement between the two halves of the PTO shaft.

OPERATING THE DITCHER



WARNING

Before making any adjustments, lubricating or repairing. First, disengage the tractor's PTO and wait for the cutter head and cutting blades to come to a complete stop. Then slowly lower the ditcher until skid shoe is touching the ground. Before dismounting from the tractor shut off the engine set the parking brake and remove the key.



CAUTION

Make certain there are no underground utilities or pipelines in the area where the ditcher will be operated. If you are not sure contact your local utilities so they can mark the area. If underground utilities or pipeline are buried in the area of operation it is important to ask how close to the locator markers the ditcher can be operated.



CAUTION

Soil and debris will be thrown out on the left side of the ditcher. Soil can be thrown in a 50' pattern from the left side of the ditcher. Rocks and other debris can be thrown farther. Make sure no person, building or vehicle is within 150' of either side of the ditcher when it is being operated.



CAUTION

Do not use the ditcher to grind tree stumps or for anything else other than moving soil. Severe damage could result if the ditcher is used for any application other than moving soil.

1. Make sure the cutter head and cutting blades are not making contact with the soil before engaging the PTO.
2. To start the ditcher throttle the tractor engine speed to 250 RPMs, lower the ditcher to slightly above the ground and engage the tractor PTO.
3. After the cutter head has started rotating, set the engine speed as follows: 540 RPM PTO speed for the 540 RPM rated ditcher models. 1000 RPM PTO speed for the 1000 RPM rated models.



WARNING

Never operate the ditcher above its RPM rating; Excessive PTO speed can cause personal injury or damage to your tractor and ditcher.

3. If the tractor is equipped with a float position on the 3-point lift it should be used. This will allow the skid shoe to control the depth of cut.
4. Slowly move the tractor forward while slowly lowering the ditcher until it has reached the set working depth.
5. Forward speed and depth of cut should be matched to soil condition. It is best not to exceed a 6" working depth on a single pass.
6. The ditcher must be raised to clear the soil surface before making sharp turns or backing up.
7. The ditcher should never be raised to maximum height with the PTO engaged.
8. Operate the ditcher at a 2.5-5 mph for best performance. Ground speed will vary for various soil types especially in extreme rocky conditions. Rule of thumb for all conditions, the slower the ground speed the better the ditcher will perform.

TRANSPORTATION

CAUTION

Always comply with all federal, state and local laws when traveling on public roads whether at night or during the day. Use accessory lights and devices for adequate warning to operators of other vehicles.

CAUTION

Always disengage PTO shaft before raising the ditcher to the transport position.

1. When raising the ditcher to transport, be sure that the driveline does not contact tractor or implement and the parking stand is pinned in the fully up position.
2. Be sure to reduce tractor ground speed when turning. Leave enough clearance so that the ditcher does not contact obstacles such as buildings, trees, or fences.
3. Select a safe ground travel speed when transporting from one area to another. When traveling on roadways, transport in such a way that faster moving vehicles may pass you safely.
4. When traveling over rough or hilly terrain, shift tractor to a lower gear.

MAINTENANCE & LUBRICATION

WARNING

Before making any adjustments, inspections, lubricating or repairing. First, disengage the tractor's PTO and wait for the cutter head and cutting blades to come to a complete stop. Then slowly lower the ditcher until skid shoe is touching the ground. Before dismounting from the tractor shut off the engine set the parking brake and remove the key.

CAUTION

Never clean, adjust or service when the ditcher is in motion. Block up all elevated components to prevent accidental lowering or lower to rest on the ground when adjusting or repairing.



WARNING

Replace any missing, illegible or damaged safety decals!

Daily or Every Ten (10) Hours of Operation

1. Visually check the chain case for oil leaks.
2. Visually inspect for loose or missing bolts.
3. Inspect for loose or damaged cutting blades.
4. Visually inspect the entire ditcher for worn, loose, damaged or missing parts including decals.
5. Check the cutter head to see if anything has wrapped around it.

Weekly or Every (50) Hours of Operation

1. Check the chain case oil level. Use quality 90 weight oil when adding oil. The oil level should be to the bottom of the check plug.
2. Lubricate all PTO shaft fittings with a good quality lithium soap grease.

Every Season or (250) Hours of Operation

1. Inspect for worn or damaged parts. Replace all worn or damaged parts.
2. Drain the oil from the chain case and flush the case with kerosene or diesel fuel to remove contamination. Fill the chain case with 3 quarts of quality grade 90 weight oil or until it reaches the bottom of the check plug. Dispose of the used oil and flushing fluid in an environmental friendly manner.
3. Inspect the chain, sprockets and bearings for wear. Replace worn or damaged parts.
4. Inspect the PTO shaft for worn or damaged parts. Replace worn or damaged parts.
5. Inspect the cutting blades. Replace the blades if worn or damaged. Note: All ditchers starting with serial number S010038 are equipped with reversible cutting blades for a longer wear life.
6. Thoroughly inspect the entire ditcher for missing, worn or damaged parts including missing decals. Repair or replace parts during the "off season" to assure dependable, trouble-free performance during the use season.

DRIVE CHAIN AND IDLER SPROCKET ADJUSTMENT



WARNING

Before making any adjustments, lubricating or repairing: First, disengage the tractor's PTO and wait for the cutter head and cutting blades to come to a complete stop. Then slowly lower the ditcher until skid shoe is touching the ground. Before dismounting from the tractor shut off the engine set the parking brake and remove the key.

1. Using a 9/16" wrench, remove 10 bolts that are in the top plate. Clean both the chain case and top plate removing old gasket.
2. Inspect drive chain, sprockets, and idler bracket for wear. If worn, replace with new parts.
3. To tighten the drive chain, first loosen the idler sprocket jam nut located on the right hand side of the vertical ditcher and on the bottom side of the offset ditcher. This requires a 3/4" wrench. Back the jam nut off to allow set screw adjustment.
4. Using a small 1/2" wrench, turn the set screw clockwise to tighten the idler sprocket against the drive chain.
5. There will be very little slack in the drive chain. Rotate the cutter head to make sure chain is tight. ***NOTE*** over tightening of the drive chain can cause major damage to the ditcher drive mechanism.
6. Once the drive chain is set to the correct tension, turn the set screw 1/4 turn counter clockwise.
7. Holding the set screw with a 1/2" wrench, tighten the jam nut using a 3/4" wrench.
8. Apply a new top plate gasket.
9. Reinstall the 10 bolts and tighten with a 9/16" wrench.

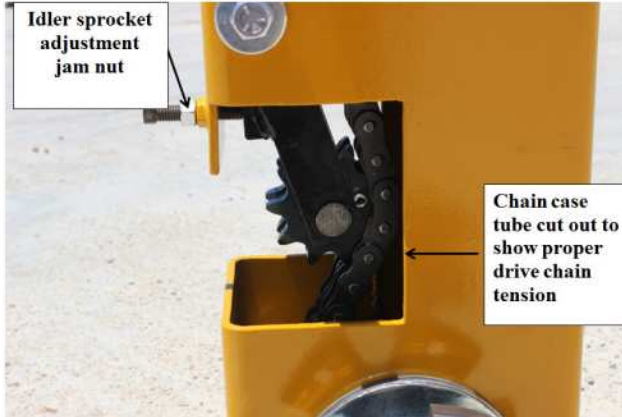

LEVELING THE DITCHER



WARNING

Before making any adjustments, lubricating or repairing:
 First, disengage the tractor's PTO and wait for the cutter head and cutting blades to come to a complete stop. Then slowly lower the ditcher until skid shoe is touching the ground. Before dismounting from the tractor shut off the engine set the parking brake and remove the key.



CAUTION

Never tilt the ditcher backwards. Operating the ditcher tilted back will result in excessive wear on the back side of the cutter head. Plus, it will increase horsepower requirements.

Vertical Chain Case Ditcher Models

Lower the ditcher to the normal operating position and extend or retract the tractor's center link until the chain case is vertical.

Offset Chain Case Ditcher Models

Lower the ditcher to the normal operating position and extend or retract the tractor's center link until the side of the chain case the skid shoe is mounted to is vertical.

FLAT & CONCAVED SKID SHOE ADJUSTMENT

WARNING

Before making any adjustments, lubricating or repairing: First, disengage the tractor's PTO and wait for the cutter head and cutting blades to come to a complete stop. Then slowly lower the ditcher until skid shoe is touching the ground. Before dismounting from the tractor shut off the engine set the parking brake and remove the key.

For the initial setting both flat and concaved skid shoes are adjusted the same regardless if they are equipped with an adjusting ratchet or adjusting bar. Initially adjust the bottom of the skid shoe so it positioned 1/2" to 1" above the bottom of the cutting blades. This will allow the ditcher to reach normal cutting depth after a few feet of forward travel. The adjusting ratchet or adjusting bar should then be adjusted as required to hold a uniform cutting depth. To achieve a deeper ditch raise the skid shoe. Lower the skid shoe to shallow up the ditch.

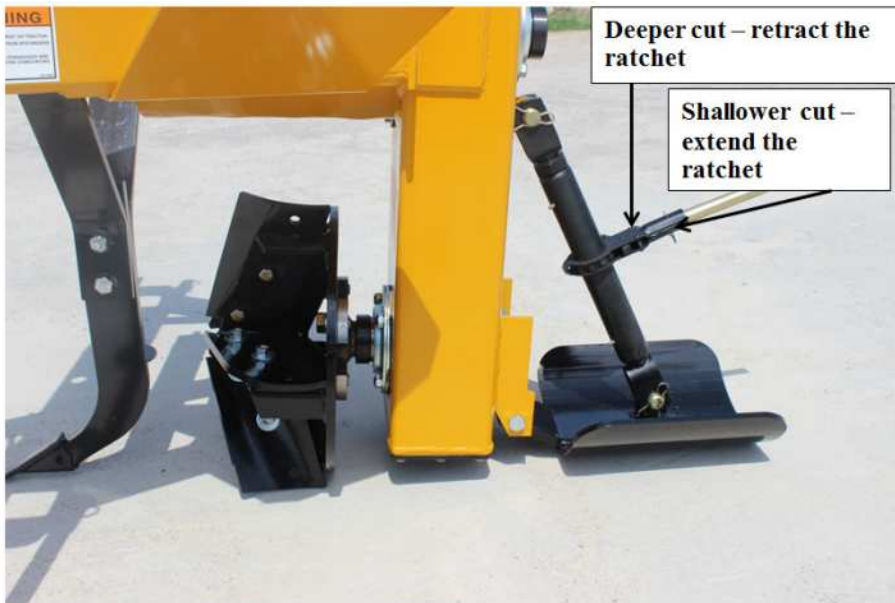

CUTTER HEAD & CUTTING BLADES

WARNING

Before making any adjustments, lubricating or repairing:
First, disengage the tractor's PTO and wait for the cutter head and cutting blades to come to a complete stop. Then slowly lower the ditcher until skid shoe is touching the ground. Before dismounting from the tractor shut off the engine set the parking brake and remove the key.

WARNING

Never operate the ditcher with out-of-balance cutting blades. Check to make certain all cutting blades are installed using the same mounting holes for either the 18" diameter or 26" diameter cutter heads.

1. Make sure the cutter head and cutting blades are not making contact with soil before engaging the PTO.
2. Do not operate the ditcher with missing or damaged cutting blades.
3. Check the cutter head and cutting blades for soil build up.
4. Check the cutter head and output shaft for wrapped wire or twine.

Smaller cutting head 18" – 20"

The cutting diameter may be adjusted by moving the location of the blades on the cutter head. Locating the blades in the inside set of holes on the smaller cutting head will give an 18" diameter cut. Locating the blades in the outside set of holes will give a 20" diameter cut.

Larger cutting head 24" – 26"

The cutting diameter may be adjusted by moving the location of the blades on the cutter head. Locating the blades in the inside set of holes on the larger cutting head will give a 24" diameter cut. Locating the blades in the outside set of holes will give a 26" diameter cut.

DITCHER EXTENDED STORAGE



CAUTION

Raise the ditcher high enough so the skid shoe can be adjusted and both parking stands can be secured in the holes that match the size of the cutter head. Before dismounting from the tractor shut off the engine set the parking brake and remove the key.

1. Before unhitching the ditcher from the tractor clean off any dirt or debris that may have accumulated on the ditcher and moving parts. Scrape off any compacted dirt from the cutter head and cutting blades. Then use a power washer to clean the ditcher.
2. Thoroughly inspect the entire ditcher for missing, worn or damaged parts including decals. Repair or replace parts during the “off season” to assure dependable, trouble-free performance during the use season.
3. Lubricate the ditcher as detailed in the Maintenance & Lubrication section of this manual.
4. Apply a protective coating to the cutter head and cutting blades.
5. The ditcher should be stored on a solid flat surface in a dry location. It is best to store the ditcher inside a storage building. Doing so will reduce future maintenance requirements and prolong the life of the ditcher.
6. To complete unhitching from the tractor follow the instructions in the Unhitching From The Tractor section in this manual.

TROUBLESHOOTING GUIDE

Problem	Cause	Solution
PTO shaft vibrates	Check for worn out universal joints	Replace universal joint if needed
	Check for bent PTO shaft	Replace PTO shaft if it is bent
Ditcher is not achieving desired cutting depth	Ditcher cutting depth is restricted by tractor 3-point	Adjust tractor 3-point lift arms to a deeper depth setting. The skid shoe maybe out of adjustment. Raise for a deeper cut
	Ditcher chain gear case needs to be adjusted so the cutting head is running parallel to the soil surface	Adjust 3-point hitch center link to align cutting head
Cutting head will not rotate	PTO shaft is not engaged	Engage PTO shaft
	PTO shaft shear bolt maybe sheared	Replace shear bolt
	Drive chain may be broken or has jumped off the drive sprockets	Repair drive chain or realign on drive sprockets and adjust tension.
Excessive noise in chain gear case. (some noise will be present during normal operation)	Drive chain is loose	Tighten idler sprocket to remove slack in chain tension
	Sprocket to chain alignment	Adjust sprocket to chain alignment
Ditcher gear case has excessive vibration	Cutting head is out of balance	Check for unevenly worn or missing cutting blades. Check for soil or other debris build up on the cutting head
Cutting blades do not leave a smooth soil surface	Check the cutting blades cutting edges for wear.	If the cutting blades are reversible rotate them. If not or completely worn out replace them.

AD-540-V

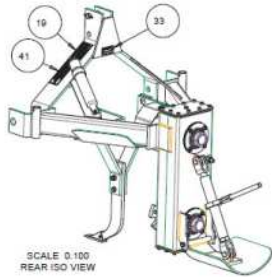

Key	Qty.	Part No	Description
19	1	10949	Decal - "Warning"
33	1	11713	Serial Plate
41	1	12141	Decal - "Warning"

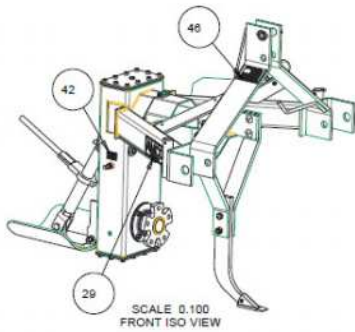

Key	Qty	Part No	Description
29	1	11465	Decal - "AMCO" logo
42	1	12212	"Caution" Decal-"Warning"
46	1	19021	Made in USA Decal

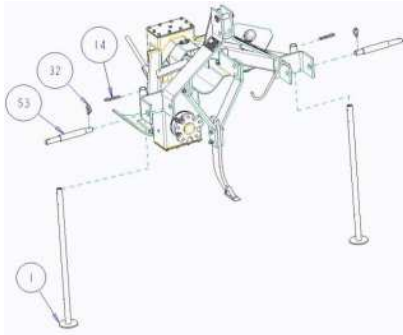

Key	Qty	Part No	Description
1	2	0939	Parking Stand Ass'y
14	2	10803	Hair Pin - #19
32	2	11697	Klik Pin 7/16
53	2	101739	Lower Hitch Pin

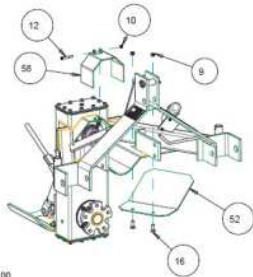

Key	Qty	Part No	Description
9	2	10395	1/2-13 Lock Hex Nut SP
10	1	10509	3/8-16 Lock Hex Nut ZP
12	1	10765	3/8-16 x 2-1/2 HHCS Gr 5 ZP
16	2	10870	1/2-13 x 1.5 Carriage Bolt Gr 5 ZP
52	1	100699	Deflector
58	1	103363	Shield

AD-540-V

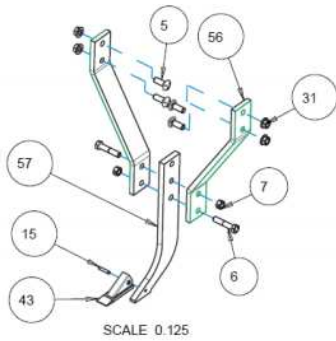

Key	Qty.	Part No	Description
5	4	10135	5/8-11 x 1-3/4 Car Blt. Gr 5, ZP
6	2	10201	5/8-11 x 3 HHCS Gr 5, ZP
7	2	10299	5/8-11 Lock Hex Nut ZP
15	1	10856	5/16 x 1 -1/2 Roll Pin ZP
31	4	11647	5/8 NC Grade "G" Flange Locknut ZP
43	1	12443	Point
56	1	102676	Hanger Bracket
57	1	102698	Shank

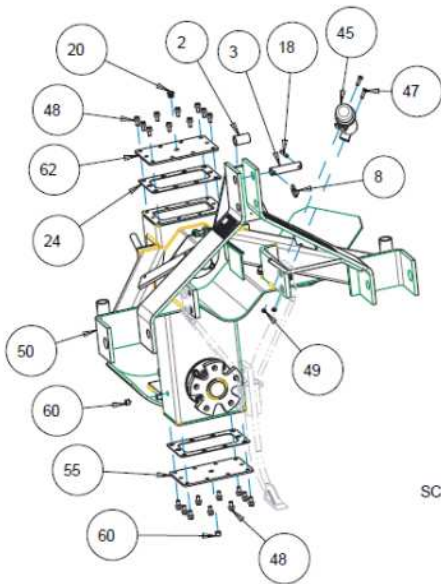

SCA

Key	Qty.	Part No	Description
2	1	6570	Bushing
3	1	7397	Connecting Pin
8	1	10317	Klik Pin 1/4"
18	1	10910	5/16 X 2-1/4 Roll Pin ZP
20	10	11293	Breather
24	2	11359	Frame Gasket
45	1	19013	Operator's Manual Holder (small)
47	2	19064	5/16-18 x 1 HHCS Gr 5 ZP
48	20	19065	5/16-18 Lock Hex Nut
49	2	19067	5/16-18 Lock Hex Nut ZP
50	1	21064	Ditcher Frame W.A.
55	1	102445	End Plate
60	2	A1115	Pipe Plug
62	1	12-0005	Top Plate W.A.

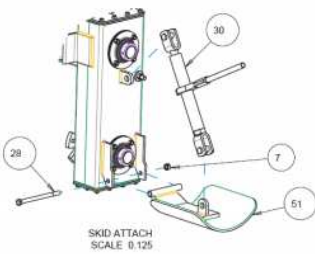

Key	Qty.	Part No	Description
7	1	10299	5/8-11 Lock Hex Nut ZP
28	1	11392	5/8-11 x 9 HHCS Gr 5 ZP
30	1	11494	Ratchet Jack @ 21.20" CL-CL
51	1	21070	Curved Skid W.A.

AD-540-V

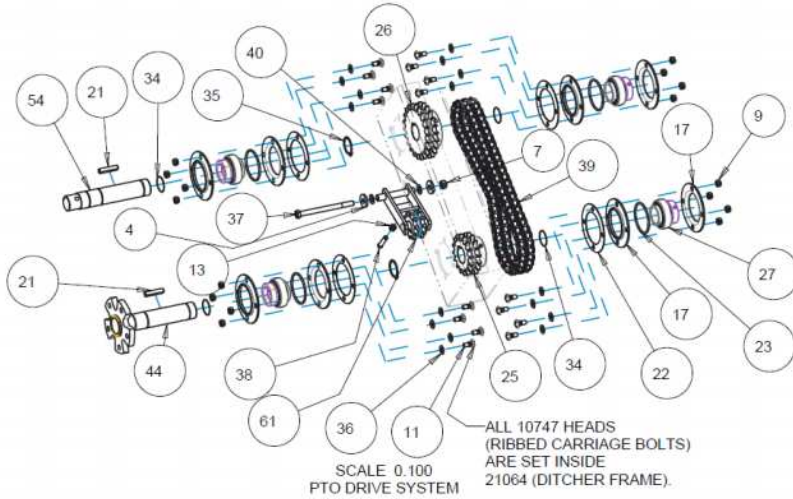

Key	Qty.	Part No	Description
4	2	10059	5/8 Std Flat Washer ZP
7	1	10299	5/8-11 Lock Hex Nut ZP
9	16	10395	1/2-13 Lock Hex Nut ZP
11	16	10747	1/2 x 1-1/4 Rib Neck Car Blt
13	1	10787	1/2-13 Hex Nut ZP
17	8	10905	Flangette
21	2	11295	Key 1/2 x 1/2 x 2-3/4"
22	4	11328	Flangette Gasket, 100MM
23	4	11329	O Ring
25	1	11375	Sprocket 16 Tooth
26	1	11376	Sprocket 22 Tooth w/ Washers
27	4	11381	Bearing & Collar
34	4	11979	O Ring
35	2	11988	SH Rings-Rotor Clip, External Ring
36	16	12017	Gasket
37	1	12095	5/8-11 x 8 HHCS Gr 5 ZP
38	1	12096	Square HD 1/2 x 2.50 Gr 5 PTF
39	1	12115	Chain #80-2 56 Pitches
40	2	12116	Washer 1-1/4 OD x 11/16 ID
44	1	18004	Output Shaft W.A.
54	1	102443	Input Shaft
61	1	05-0017	Idler Sprocket Ass'y

AD-1000-V

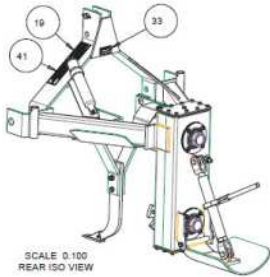

Key	Qty.	Part No	Description
19	1	10949	Decal – “Warning”
33	1	11713	Serial Plate
41	1	12141	Decal – “Warning”

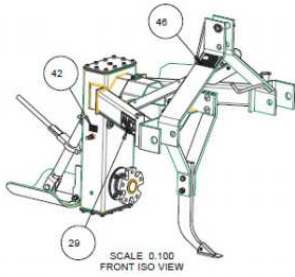

Key	Qty	Part No	Description
29	1	11465	Decal – “AMCO” logo
42	1	12212	“Caution” Decal-“Warning”
46	1	19021	Made in USA Decal

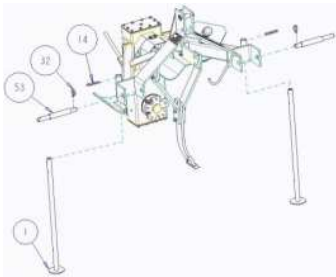

Key	Qty	Part No	Description
1	2	0939	Parking Stand Ass’y
14	2	10803	Hair Pin - #19
32	2	11697	Klik Pin 7/16
53	2	101739	Lower Hitch Pin

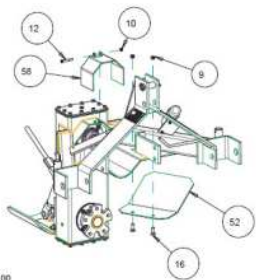

Key	Qty	Part No	Description
9	2	10395	½-13 Lock Hex Nut SP
10	1	10509	3/8-16 Lock Hex Nut ZP
12	1	10765	3/8-16 x 2-1/2 HHCS Gr 5 ZP
16	2	10870	½-13 x 1.5 Carriage Bolt Gr 5 ZP
52	1	100699	Deflector
58	1	103363	Shield

L100

AD-1000-V

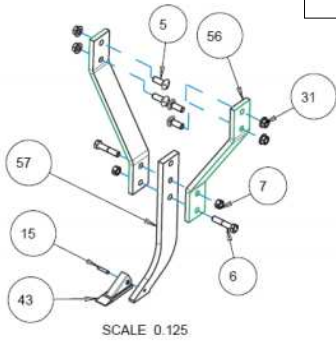

Key	Qty.	Part No	Description
5	4	10135	5/8-11 x 1-3/4 Car Blt. Gr 5, ZP
6	2	10201	5/8' 11 x 3 HHCS Gr 5, ZP
7	2	10299	5/8-11 Lock Hex Nut ZP
15	1	10856	5/16 x 1 -1/2 Roll Pin ZP
31	4	11647	5/8 NC Grade "G" Flange Locknut ZP
43	1	12443	Point
56	1	102676	Hanger Bracket
57	1	102698	Shank

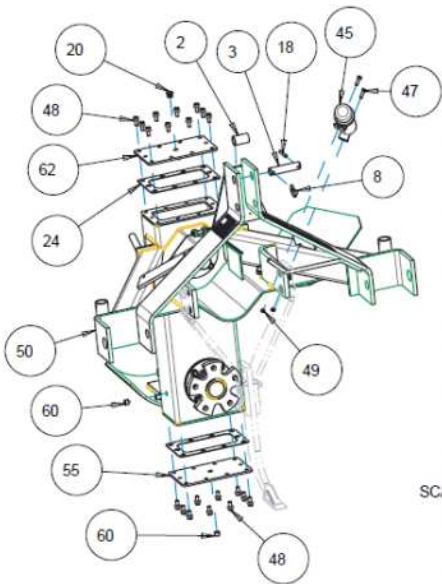

Key	Qty.	Part No	Description
2	1	6570	Bushing
3	1	7397	Connecting Pin
8	1	10317	Klik Pin 1/4"
18	1	10910	5/16 X 2-1/4 Roll Pin ZP
20	1	11293	Breather
24	2	11359	Frame Gasket
45	1	19013	Operator's Manual Holder (small)
47	2	19064	5/16-18 x 1 HHCS Gr 5 ZP
48	20	19065	5/16-18 Lock Hex Nut
49	2	19067	5/16-18 Lock Hex Nut ZP
50	1	21064	Ditcher Frame W.A.
55	1	102445	End Plate
60	2	AH115	Pipe Plug
62	1	12-0005	Top Plate W.A.

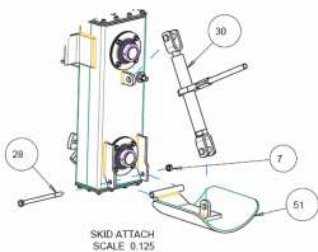

Key	Qty.	Part No	Description
7	1	10299	5/8-11 Lock Hex Nut ZP
28	1	11392	5/8-11 x 9 HHCS Gr 5 ZP
30	1	11494	Ratchet Jack @ 21.20" CL-CL
51	1	21070	Curved Skid W.A.

AD-1000-V

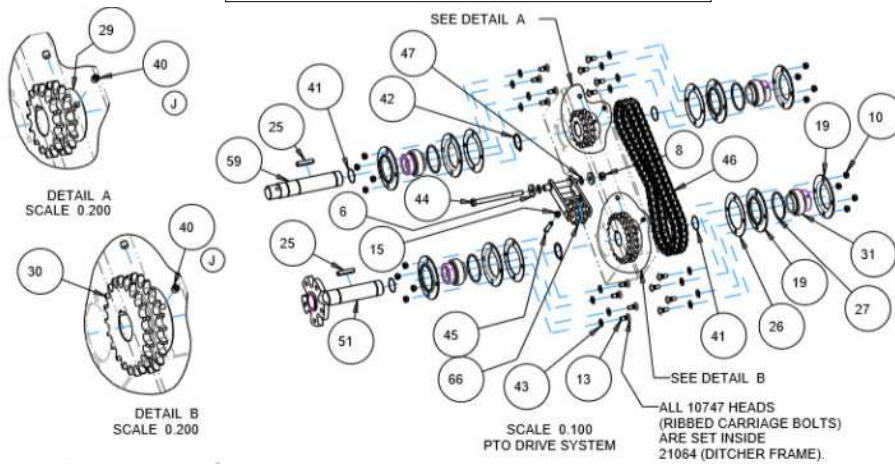

Key	Qty.	Part No	Description
4	2	10059	5/8 Std Flat Washer ZP
7	1	10299	5/8-11 Lock Hex Nut ZP
9	16	10395	1/2-13 Lock Hex Nut ZP
11	16	10747	1/2 x 1-1/4 Rib Neck Car Blt
13	1	10787	1/2-13 Hex Nut ZP
17	8	10905	Flangette
21	2	11295	Key 1/2 x 1/2 x 2-3/4"
22	4	11328	Flangette Gasket, 100MM
23	4	11329	O Ring
25	1	11375	Sprocket 16 Tooth
26	1	11376	Sprocket 22 Tooth w/ Washers
27	4	11381	Bearing & Collar
34	4	11979	O Ring
35	2	11988	SH Rings-Rotor Clip, External Ring
36	16	12017	Gasket
37	1	12095	5/8-11 x 8 HHCS Gr 5 ZP
38	1	12096	Square HD 1/2 x 2.50 Gr 5 PTF
39	1	12115	Chain #80-2 56 Pitches
40	2	12116	Washer 1-1/4 OD x 11/16 ID
44	1	18004	Output Shaft W.A.
54	1	102443	Input Shaft
61	1	05-0017	Idler Sprocket Ass'y

AD-540-OS

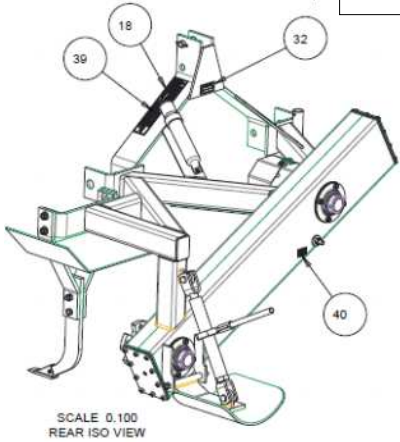

Key	Qty.	Part No	Description
18	1	10949	Decal – “Warning”
32	1	11713	Serial Plate
39	1	12141	Decal – “Warning”
40	1	12212	“Caution” – Decal – “Warning”

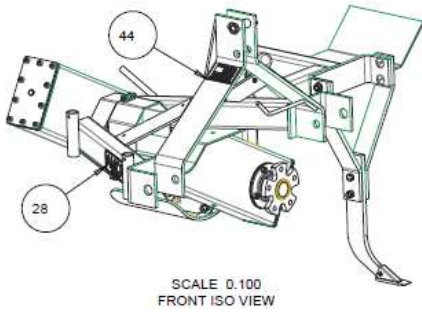

Key	Qty	Part No	Description
28	1	11465	Decal – “AMCO” logo
44	1	19021	Made in USA Decal

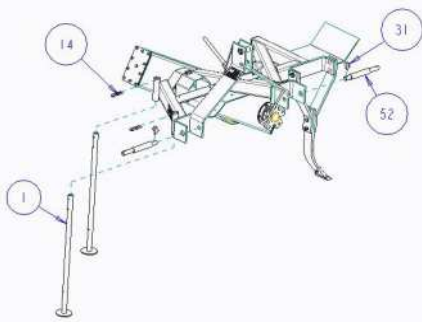

Key	Qty	Part No	Description
1	1	0939	Parking Stand Ass’y
14	1	10803	Hair Pin - #19
31	1	11697	Klik Pin 7/16
52	1	101739	Lower Hitch Pin

AD-540-OS

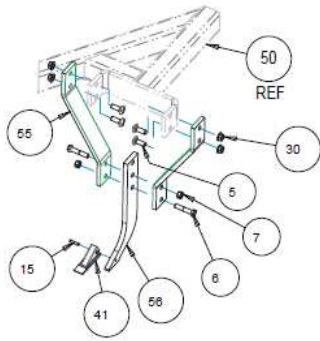

SCALE 0.100

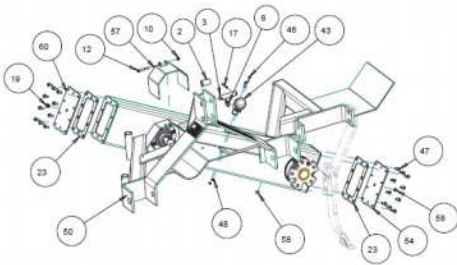

SCALE 0.100

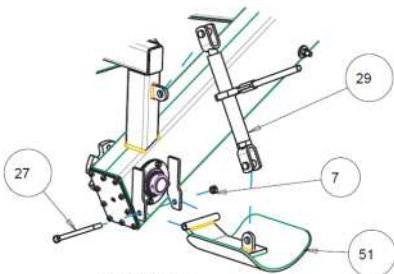

SKID ATTACH
SCALE 0.100

Key	Qty.	Part No	Description
5	4	10135	5/8-11 x 1-3/4 Car Blt. Gr 5, ZP
6	2	10201	5/8' 11 x 3 HHCS Gr 5, ZP
7	2	10299	5/8-11 Lock Hex Nut ZP
15	1	10856	5/16 x 1 -1/2 Roll Pin ZP
30	4	11647	5/8 NC Grade "G" Flange Locknut ZP
41	1	12443	Point
50	1	21068	Offset Ditcher Frame W.A.
55	2	102676	Hanger Bracket
56	1	102698	Shank

Key	Qty.	Part No	Description
2	1	6570	Bushing
3	1	7397	Connecting Pin
8	1	10317	Klik Pin 1/4"
10	1	10509	3/8-16 Lock Hex Nut ZP
12	1	10765	3/8-16 x 2-1/2 HHCS Gr 5 ZP
17	1	10910	5/16 x 2 1/4 Roll Pin ZP
19	1	11293	Breather
23	2	11359	Frame Gasket
43	1	19013	Operator's Manual Holder (small)
46	2	19064	5/16-18 x 1 HHCS Gr 5 ZP
47	20	19065	3/8-16 x 3/4 Serrated HFCS Gr 5
48	2	19067	5/16-18 Lock Hex Nut ZP
50	1	21068	Offset Ditcher Frame W.A.
54	1	102445	End Plate
57	1	103363	Shield
58	2	A1115	Pipe plug-3/8"
60	1	12-005	Top Plate W.A.

Key	Qty.	Part No	Description
7	1	10299	5/8-11 Lock Hex Nut
27	1	11392	5/8-11 x 9 HHCS Gr 5 ZP
29	1	11494	Ratchet Jack @ 21.20" CL-CL
51	1	21070	Curved Skid W.A.

AD-540-OS

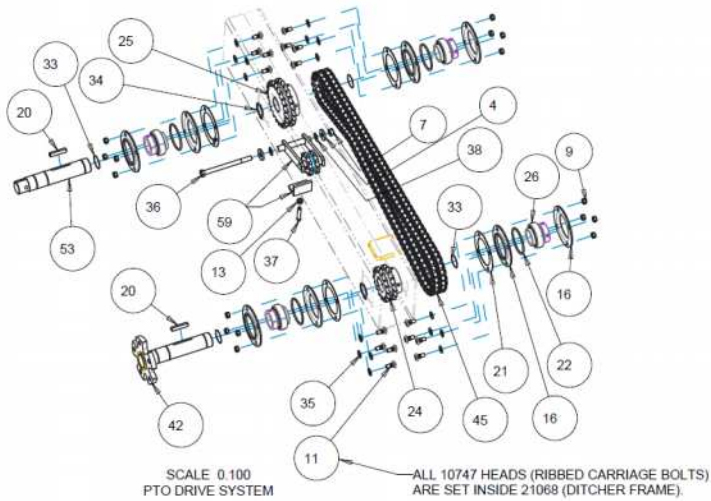

Key	Qty.	Part No	Description
4	1	10059	5/8 Std Flat Washer ZP
7	1	10299	5/8-11 Lock Hex Nut ZP
9	16	10395	1/2-13 Lock Hex Nut ZP
11	16	10747	1/2 x 1-1/4 Rib Neck Car Blt
13	1	70787	1/2-13 Hex Nut ZP
16	8	10905	Flangette
20	1	11295	Key 1/2 x 1/2 x 2-3/4"
21	4	11328	Flangette Gasket, 100MM
22	4	11329	O Ring
24	1	11375	Sprocket 16 Tooth
25	1	11376	Sprocket 22 Tooth w/ Washers
26	4	11381	Bearing & Collar
33	4	11979	O Ring
34	2	11988	SH Rings-Rotor Clip, External Ring
35	16	12017	Gasket
36	1	12095	5/8-11 x 8 HHCS Gr 5 ZP
37	1	12096	Square HD 1/2 x 2.50 Gr 5 PTF
38	2	12116	Washer 1-1/4 OD x 11/16 ID
42	1	18004	Output Shaft W.A.
45	1	19029	Chain #80-2 97 Pitches
53	1	102443	Input Shaft
59	1	05-0017	Idler Sprocket Ass'y

AD-1000-OS

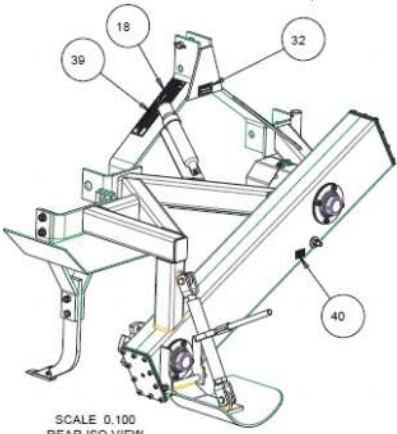

Key	Qty.	Part No	Description
18	1	10949	Decal – “Warning”
32	1	11713	Serial Plate
39	1	12141	Decal – “Warning”
40	1	12212	“Caution” – Decal – “Warning”

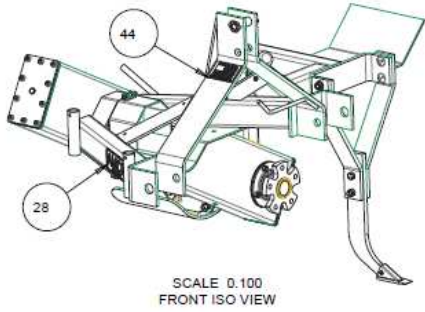

Key	Qty	Part No	Description
28	1	11465	Decal – “AMCO” logo
44	1	19021	Made in USA Decal

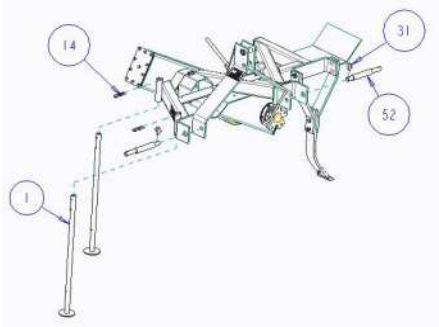

Key	Qty	Part No	Description
1	1	0939	Parking Stand Ass’y
14	1	10803	Hair Pin - #19
31	1	11697	Klik Pin 7/16
52	1	101739	Lower Hitch Pin

AD-1000-OS

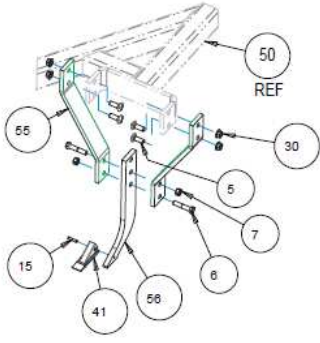

SCALE 0.100

Key	Qty.	Part No	Description
5	4	10135	5/8-11 x 1-3/4 Car Blt. Gr 5, ZP
6	2	10201	5/8' 11 x 3 HHCS Gr 5, ZP
7	2	10299	5/8-11 Lock Hex Nut ZP
15	1	10856	5/16 x 1 -1/2 Roll Pin ZP
30	4	11647	5/8 NC Grade "G" Flange Locknut ZP
41	1	12443	Point
50	1	21068	Offset Ditcher Frame W.A.
55	2	102676	Hanger Bracket
56	1	102698	Shank

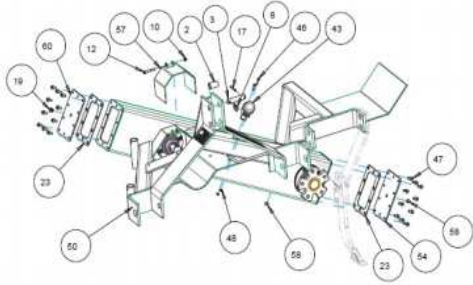

SCALE 0.100

Key	Qty.	Part No	Description
2	1	6570	Bushing
3	1	7397	Connecting Pin
8	1	10317	Klik Pin 1/4"
10	1	10509	3/8-16 Lock Hex Nut ZP
12	1	10765	3/8-16 x 2-1/2 HHCS Gr 5 ZP
17	1	10910	5/16 x 2 1/4 Roll Pin ZP
19	1	11293	Breather
23	2	11359	Frame Gasket
43	1	19013	Operator's Manual Holder (small)
46	2	19064	5/16-18 x 1 HHCS Gr 5 ZP
47	20	19065	3/8-16 x 3/4 Serrated HFCS Gr 5
48	2	19067	5/16-18 Lock Hex Nut ZP
50	1	21068	Offset Ditcher Frame W.A.
54	1	102445	End Plate
57	1	103363	Shield
58	2	A1115	Pipe Plug-3/8"
60	1	12-005	Top Plate W.A.

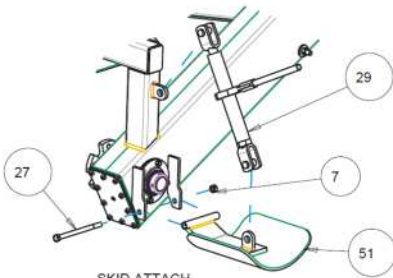

SKID ATTACH
SCALE 0.100

Key	Qty.	Part No	Description
7	1	10299	5/8-11 Lock Hex Nut ZP
27	1	11392	5/8-11 x 9 HHCS Gr 5 ZP
29	1	11494	Ratchet Jack @ 21.20" CL-CL
51	1	21070	Curved Skid W.A.

AD-1000-OS

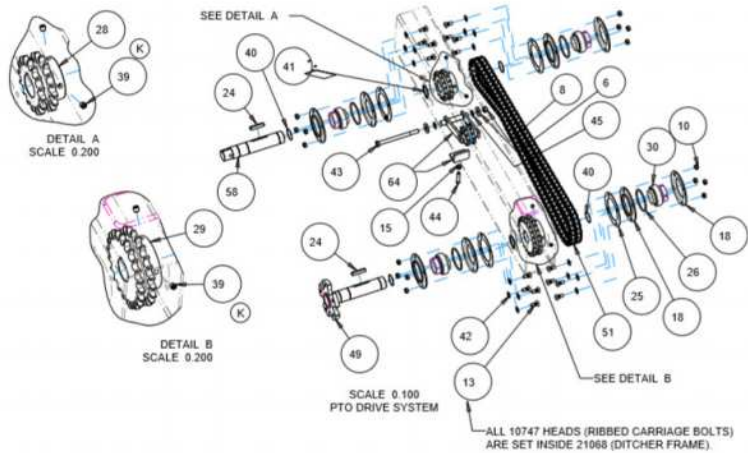

Key	Qty.	Part No	Description
4	1	10059	5/8 Std Flat Washer ZP
7	1	10299	5/8-11 Lock Hex Nut ZP
9	16	10395	1/2-13 Lock Hex Nut ZP
11	16	10747	1/2 x 1-1/4 Rib Neck Car Blt
13	1	70787	1/2-13 Hex Nut ZP
16	8	10905	Flangette
20	1	11295	Key 1/2 x 1/2 x 2-3/4"
21	4	11328	Flangette Gasket, 100MM
22	4	11329	O Ring
24	1	11375	Sprocket 16 Tooth
25	1	11376	Sprocket 22 Tooth w/ Washers
26	4	11381	Bearing & Collar
33	4	11979	O Ring
34	2	11988	SH Rings-Rotor Clip, External Ring
35	16	12017	Gasket
36	1	12095	5/8-11 x 8 HHCS Gr 5 ZP
37	1	12096	Square HD 1/2 x 2.50 Gr 5 PTF
38	2	12116	Washer 1-1/4 OD x 11/16 ID
42	1	18004	Output Shaft W.A.
45	1	19029	Chain #80-2 97 Pitches
53	1	102443	Input Shaft
59	1	05-0017	Idler Sprocket Ass'y